

Use and Maintenance Manual

Telescopic handlers **TH**_[Deutz]

YOUR DEALER:



Via Magellano, 22

41013 Castelfranco Emilia (MO) Italy

Tel +39 059 8630811 Fax +39 059 8638012

www.magnith.com

commerciale@magnith.com



Index

PREFACE	7	Roll-Over Protective Structure (ROPS), Falling Objects Protective Structure (FOPS)	18
Important information regarding safety	7	SECTION ON PRODUCT INFORMATION	19
Information regarding this Manual	7	TECHNICAL SPECIFICATIONS.....	19
Symbols used	8	DIMENSIONS.....	22
Reference regulatory framework.....	8	LOAD CHARTS	23
SAFETY AND WARNINGS SECTION.....	9	INFORMATION ON IDENTIFICATION	25
Symbols and safety labels	9	Machine identification plate	25
Do not transport persons	9	Serial No. stamped on chassis	25
Engine compartment	9	Engine identification plate	25
Danger of burns	9	Transmission identification plate	25
Internal combustion engine	10	Axles identification plate.....	25
Radiator.....	10	Cab identification plate	25
Radiator fan.....	10	FEATURES OF THE VEHICLE	26
Services compartment	10	Front Headlamps.....	26
Do not enter the operating area of the machine	10	Rear headlamps.....	26
Pressure of stabilisers on the ground	10	Work lights and emergency lights	26
Do not stand under the load	11	Rear-view mirrors.....	26
Do not approach the accessory.....	11	Quick-fit of the accessory.....	27
Speed limit on public roads.....	11	Shear pin housing (standard)	27
GENERAL INFORMATION REGARDING DANGER....	12	Anchoring points	27
Pressurised air and water.....	12	Tow hook.....	28
Penetration of fluids	12	Additional work lights (optional).....	28
Limiting the ejection of liquids.....	13	Setup for countries with cold climate (optional)	28
Information regarding asbestos.....	13	OPERATION	29
Prevention of cuts and crushing	13	Multiple function Display	29
Preventing burns.....	14	Browsing through the pages	29
Coolants	14	Adjusting the control panel intensity	30
Oils	14	Accessory confirmation page	31
Batteries.....	14	Main page.....	31
Prevention of fires and explosions.....	14	Speed.....	31
Extinguisher.....	15	Graduated indicators	32
Ether.....	15	Indicator lights.....	32
Piping.....	15	Front axle shift indicator	32
Information regarding AdBlue	15	Vehicle levelling indicator	33
AdBlue and high temperatures	15	Stabilisers page.....	33
AdBlue and low temperatures	15	Load check page	34
Storage and disposal	16	Configuration of boom	34
Regeneration.....	16	Interactive load chart	34
Accident prevention in case of thunderstorms		Load percentage.....	34
with lightning	17	Limits page	35
Spare parts and tooling.....	17	Controls page	35
Before using the vehicle.....	17	Air conditioning.....	35
Noise and vibrations	18	Work lights	35
Noise level.....	18	Built-in traction release.....	36
Vibration level.....	18	Telescopic boom suspension (optional).....	36
Protection for the operator	18	Checking the engine rpm	36
		Activation of radio control	36
		24V socket (OPTIONAL).....	36
		Auxiliary continuous function	37
		Cooling fan inversion function	37

FEATURES OF THE CAB	37	INFORMATION REGARDING TRANSPORT	57
Cab door	37	Shipping the vehicle	57
Cab window	37	Travelling by road with the machine	57
Rear window	38	Lifting and anchoring the machine	58
Emergency exit	38	Towing the vehicle	59
Seat	38		
Seat belts	39	MAINTENANCE	61
Safety keys container	40	General information	61
Air vents	40	Tightening torques	61
Vehicle radio	40	Inflating the tyres	61
Electric cigarette lighter	40	<i>Inflation with air</i>	61
220V socket in cab (optional)	41	Standard inflation pressures	62
CONTROLS	41	Washing	62
Steering column	41	Liquids and lubricants	63
Ignition switch	42	Spares for routine maintenance	64
Lights/windscreen wiper selector	42	MAINTENANCE SCHEDULE	65
Direction indicators	42	MAINTENANCE OPERATIONS	66
Lights switch	42	Transmission shaft	66
Windscreen wipers	42	Axles	66
Warning buzzer	42	Telescopic boom chains	66
Parking brake	42	Transmission belt	68
Emergency lights	43	Engine oil	68
Pedals	43	Checking the engine oil level	69
Steering modes	43	Engine oil temperature	69
Joystick	44	Replacing the lubrication oil cartridge	69
Transmission selector	44	Fuel prefilter	69
Speed	44	Fuel filter	70
Boom head hydraulic command	45	Bleed the fuel supply system	70
Control panel	46	AdBlue filter	71
USB socket	46	Coolant	71
Emergency stop button	46	Differentials oils	72
Levelling on tyres	46	Hydraulic fluid	72
Control of the stabilizers	46	Hydraulic fluid filter	73
Exclusion of the safety systems	47	Two or three-speed reduction gear oil	73
RADIO CONTROLS (OPTIONAL)	48	Wheel reduction gears oil	74
General information	48	Steering elements	74
BEFORE STARTING UP THE ENGINE	49	Engine air filter	74
Visual inspection	49	Cab air filter	75
Climbing on to or climbing down from the vehicle	49	Telescopic boom sliding blocks	75
Driver's seat	49	Telescopic boom pins	76
STARTING UP THE ENGINE	50	Emergency hydraulic pump	78
Start up in normal conditions	50	Engine radiator	78
Start up in extreme climates	50	Wheels	78
Start up using jumper cables	50	Fuel tank	79
After start up	51	Window washing liquid tank	79
Releasing the parking brake	51	Stabilizers	79
OPERATING TECHNIQUES	52	Engine Trouble-shooting	80
Fitting the fork carriage	52		
Dismantling the fork carriage	53	REFERENCE INFORMATION	91
Handling of loads	53	Leaving the vehicle unused for long periods	91
Driving the vehicle	55	Leaving the vehicle unused for less than 12 months ..	91
PARKING THE VEHICLE	56	Leaving the vehicle unused for less than 36 months	Errore. Il segnalibro
Parking position	56	Reusing the vehicle	91
Stopping the vehicle	56		
Leaving the vehicle	56		

Dismantling and disposal of the machine 91

APPROVED ACCESSORIES..... 92

DELIVERING THE FORKLIFT TRUCK TO THE CUSTOMER
..... 93

PREFACE

Important information regarding safety

Most accidents due to use, maintenance and repair of machines are caused by failure to observe the most elementary rules for safety and caution. An accident can often be avoided if the potential hazards to which one is exposed are known, and the required precautions are taken. Those working on the machine must take utmost care, and must have suitable technical skills and equipment for carrying out the various operations correctly.

Improper use, maintenance or repair of this machine can lead to accidents and even death of workers.

Use the machine or carry out maintenance or repairs on it only after having completely read and understood all the indications in this use and maintenance Manual.

The precautions and warnings regarding safety are highlighted in this Manual and on the machine by means of the informative stickers. Ignoring these warnings can result in serious accidents, or even death for the operator or other persons.

Magni Telescopic Handlers may not be able to foresee all the possible circumstances which can constitute a safety hazard. The warnings contained in this Manual or applied on the machine may not be considered as all-inclusive. In adopting procedures, equipment or methods not expressly recommended it is the operator's responsibility to make sure work is carried out in accordance with the main safety standards and in compliance with the law. Moreover, it is necessary to ensure that the machine is not rendered hazardous by accidental damage or extraordinary interventions carried out without authorisation.

Information regarding this Manual

This Manual must be considered an integral part of the machine, and must accompany it throughout its working life from the commissioning to the final disposal. It must therefore be kept safe in the spaces provided inside the machine, or in such a place as to prevent premature deterioration.

This Manual contains information regarding safety, instructions for correct use of the machine and recommendations for routine maintenance.

The information, technical specifications and instructions contained in this Manual must be considered as up to date on the date of its publication. The Manufacturer reserves the right to make modifications to the machines, their accessories and calibration at any time, without prior notification. These modifications can influence the maintenance and working of the machine. It is necessary to have the latest and complete information before starting any operation on the machine. Please contact your Magni Telescopic Handlers dealer for the latest copy of this Manual.

If the machine is fitted with optional accessories, a use and maintenance manual for the accessories will be provided together with this Manual. The use and maintenance Manual of the accessories must be considered as an integral part of the Manual; therefore it must be kept safe and consulted using the same methods and with the same care.

Symbols used

The hazard indications included in this Manual are made easily identifiable by a “warning symbol” with one or more “warning messages” alongside. A message is also present under the symbol in the form of writing or illustration, indicating the hazard and the techniques to overcome these.

An example of these hazard indications is given below:



ATTENTION

Caution is recommended because your safety and that of others is at stake!!

The symbols used in this Manual comply with standard UNI EN ISO 7010:2012. To make it easy for the user, a summary of the symbols used is given below with their brief description:



Generic danger



Danger of burns



Danger of crushing



Danger from hanging load



Electricity



Risk of intoxication



Batteries



Flammable material



Ban on smoking or lighting up any kind of naked flame

Reference regulatory framework

This Manual has been drafted in compliance with the main reference standards:

- Machinery Directive 2006/42/EC;
- UNI 10653:2003 Technical documentation – Quality of product technical documentation;
- UNI 10893:2000 Technical documentation of product – Instructions for use – Articulation and Exposition of the Content.

SAFETY AND WARNINGS SECTION

Symbols and safety labels

Several specific safety symbols are present on this machine. This section shows the exact position of the warning plates on the machine and the entity of the hazard. Those using the machine must be fully aware of the meaning of each safety symbol for rapid identification and effective prevention of risks.

Make sure all the safety symbols are present and clearly legible. Contact your dealer for missing labels, or in case of labels present but not described in this Manual. Clean illegible labels. Use a cloth, warm water and neutral soap for cleaning. Do not use solvents, petrol or abrasive chemical products for cleaning the labels. These products will irremediably damage the adhesive fixing the label to the machine.

Replace all missing or damaged safety labels. If a safety label is applied on a part of the machine that is to be replaced, make sure the spare part has a similar label. Contact your dealer for assistance in case of irreparably damaged labels, missing labels and labels present on the machine but not described in this Manual.

Do not transport persons



The safety symbol is applied near the mud guards, engine compartment and the compartment housing the tanks.

It is forbidden to carry third persons while the machine is in operation.

Engine compartment



ATTENTION

There are several sources of risk inside the engine compartment which can cause serious injury or even death.

Do not approach or touch any part inside the engine compartment without protective equipment and adequate technical training.

Do not disconnect the high pressure tubes. The liquid trapped inside can leak out with considerable pressure that could pierce the tissues, causing serious injury.

Do not touch the electric wiring or short circuit these. The current in the electric wiring is high voltage and can cause explosions or damage tissues if short circuited.

There are scorching hot surfaces and flammable and explosive materials inside the engine compartment. Do not allow contact between the scorching hot surfaces and flammable material.

Danger of burns



This safety symbol is present on the outside of the engine compartment.

The surfaces near the engine can get heated to temperatures exceeding 100° C.

Serious burns can be caused if the skin comes in contact with these surfaces.

Do not touch the engine compartment and the parts inside it without making sure they have cooled down.

Internal combustion engine



ATTENTION

The engine has tubing under high pressure. Liquid leakage can penetrate the tissues causing even serious injuries.

Do not try to repair the high pressure tubing.

Carefully read the Use and Maintenance Manual before starting up the engine or carrying out maintenance or repairs.

Radiator

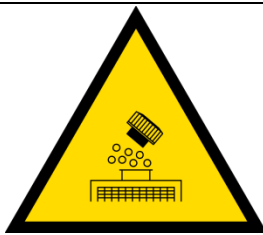

This safety symbol is present on the upper part of the radiator, inside the engine compartment.

Do not unscrew the radiator cap when the coolant is still hot. The hot coolant is also pressurised, and unscrewing the cap will cause ejection of boiling steam jets with risk of even serious injuries.

Radiator fan

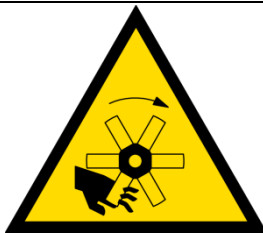

This safety symbol is present on the radiator surface near the cooling fan.

Do not touch the radiator fan with the engine running.

The fast moving fan blades can cause severe tearing or even cut the limbs.

Services compartment

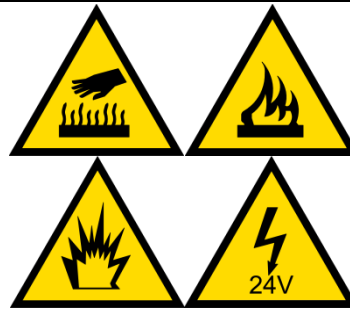

The safety symbols shown in the Figure are applied inside the services compartment on the RH.



ATTENTION

There are several sources of risk inside the engine compartment which can cause serious injury or even death.

Do not touch any part inside the compartment without protective equipment and adequate technical training.

Do not touch the electric wiring or short circuit these. The current in the electric wiring is high voltage and can cause explosions or damage tissues if short circuited.

Do not enter the operating area of the machine



DANGER OF CRUSHING

Do not approach the machine while it is working.

Pressure of stabilisers on the ground



This safety symbol is applied on both stabilisers.

Always make sure the ground is capable of withstanding the load applied by the stabilisers. Yielding of the ground can affect the stability of the vehicle. If the stability is affected the result can be loss of load, and in extreme cases even tilting over of the machine.

Do not stand under the load



This safety symbol is positioned at the top of the telescopic boom.



HANGING LOAD

If the hanging load falls to the ground it can cause serious injuries or death to persons present in the area underneath.

Never stand in the area under a hanging load.

Do not approach the accessory

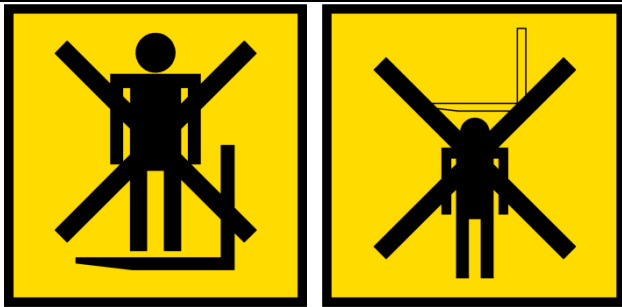

This safety symbol is applied at the top of the telescopic boom, on the LH, near the quick-fit system for the accessories.

Do not approach the accessory fitted at the top of the boom during the working of the machine. In particular, do not climb on the accessory, and do not stand in the area under it.

Speed limit on public roads



These symbols applied on the sides and at the back of the vehicle indicate the maximum speed permitted for road travel, depending on the country of use.

Do not exceed the speed indicated for travelling on public roads.

Ignoring this warning can be a risk for the safety of the operator, vehicle and for objects and/or persons present in the vicinity.

The operator who ignores this warning may face administrative and/or criminal penalties. The entity of these penalties depends on the road rules in force in the country in which the vehicle is used.

GENERAL INFORMATION REGARDING DANGER



Fit a “**DO NOT OPERATE**” or similar tag to the start up switch or to the controls before carrying out maintenance or repairs on the machine.

The machine must be used only by suitably qualified trained personnel. Driving permission must be issued by the work site manager where the vehicle is to be used. The driving permit is strictly personal and must not be used by others.

Note the vehicle dimensions in order to be able to keep at a safety distance from surrounding obstacles during use.

Pay attention to the presence of high voltage lines, both overhead and underground. In case of contact between the machine and high voltage electricity lines, there may be intense electric shocks which can cause injuries, even fatal.



Wear the personal protective equipment necessary for the type of operations to be carried out.

Do not wear loose clothing, jewellery or metal objects which can get entangled in the controls or other parts of the machine.

Make sure all the guards and covers are fitted correctly on the machine.

Keep the machine in perfect working condition by carrying out the scheduled maintenance punctually and scrupulously.

Unless otherwise specified, carry out the maintenance operations with the vehicle in the maintenance position.

Dispose of the used liquids in compliance with the regulations in force in the country where the vehicle is used.

Clean the vehicle daily. Remove debris, oil, tools and other objects from the steps, passages and treading surfaces.



NO SMOKING

Do not smoke or light naked flames under any circumstances whatsoever.

Naked flames in contact with fuel, oil or solvents present on the vehicle or necessary for its maintenance can cause injuries, even mortal.

Inhalation of gases produced by a flame or contact with coolant gas can cause injury to the respiratory airways, even mortal.

Pressurised air and water

Pressurised water can cause injury to tissues, especially if accompanied by debris. Compressed air can cause injuries.

If water or compressed air is used for cleaning operations, wear suitable protective equipment, in particular for sensitive organs like the eyes.

The maximum air pressure for cleaning must be less than 2 bar. The maximum water pressure must be less than 3 bar.

Penetration of fluids

The pressure values in the hydraulic circuit may remain high for a long time even after the vehicle is switched off. If not discharged properly, the pressure can cause violent ejection of oil and objects.

Do not disconnect or dismantle any of the hydraulic components if the pressure has not been discharged correctly, as this can lead to serious accidents.

Refer to the maintenance section of this Manual for the methods for discharging the hydraulic pressure correctly.

Limiting the ejection of liquids

It is necessary to deal with the leakage of liquids during the operations carried out on the vehicle. Provide suitable containers for the liquids before acting on any component of the vehicle containing fluids.

Dispose of the liquids used in compliance with the regulatory standards in force in the country in which the vehicle will be used.

Information regarding asbestos

Magni T.H. products and spare parts are asbestos-free. Using non genuine spare parts can lead to risk of handling products containing asbestos.

Avoid inhaling dusts which may be produced when handling components containing asbestos fibres. Inhaling these dusts can be harmful for health. The non original components which may contain asbestos are the friction elements of the brakes and clutches, linings and types of gaskets. The asbestos used in these components is generally immersed in resin or sealed in another manner. Normal handling is not hazardous as long as suspended dusts are not produced.

If dusts containing asbestos are present, the following precautions must be taken:

- Do not use compressed air for cleaning;
- Avoid brushing materials containing asbestos;
- Avoid grinding materials containing asbestos;
- Use wet cleaning methods for parts containing asbestos;
- Equip the work area with appropriate air extractors;
- If there are no other methods for controlling the dusts, wear a suitable respiratory mask;
- Avoid areas where asbestos particles may be present in the air.

Prevention of cuts and crushing



Support the attachment adequately before carrying out any kind of work on it. Do not rely on hydraulic jacks for supporting the accessory: these may fall if a tube breaks or in case of involuntary activation.

Do not try to make any adjustment while the vehicle is in motion or with the engine switched on, unless otherwise specified.

Avoid tampering with the electrical system of the machine to try starting up the engine. This may cause involuntary movements of the attachment.

Keep at a safe distance while operating the equipment using the control levers. Increase the safety distance if there is a possibility of the moving parts making rapid and sudden movements.

If it is necessary to remove the safety devices fitted on the vehicle to carry out maintenance or repairs, always refit these at the end of operations.

Keep limbs away from the moving fan blades. The fast moving blades are comparable to sharp blades, and can cause serious tears. Keep small objects away from the moving fan blades. The blades may throw off these objects at high speed, making it dangerous for the safety of persons.

Do not use frayed or bent steel cables. Always wear protective gloves while handling steel cables.

If a pin is tapped with great force, it may come out of its seat suddenly. A pin thrown off with force can cause serious injuries to persons in the vicinity. If tapping on a pin, make sure there is no one in the surrounding area.

Preventing burns



Do not touch the engine or any components directly connected to it during operation. Allow the engine to cool down before carrying out any maintenance. Before disconnecting any component of the hydraulic or pneumatic circuits, make sure all the residual pressure has been discharged from the circuit.

Coolants

When the engine is at operating temperature, the coolant is very hot and at high pressure. The radiator and all the piping connected to it are filled with hot coolant under pressure.

Contact with the hot coolant or with vapour can cause serious injuries. Allow the entire cooling system to cool down before carrying out any intervention.

Before removing the radiator cap, make sure it is not hot. Remove the radiator cap slowly to discharge the residual pressure.

The liquid in the cooling system contains HFC (hydrofluorocarbons). At ambient temperature and pressure the HFC released in the air can cause asphyxia. Do not handle HFC in the presence of naked flames. HFC at high pressure or temperature can give rise to toxic and corrosive chemical agents. Always use appropriate personal protective equipment during operations involving HFC.

Oils

Oil and components at high temperature can cause burns. Do not allow boiling hot oil to come in contact with the skin. Do not touch hot components.

Remove the hydraulic fluid tank cap only after stopping the engine. Make sure the cap is cold enough to be touched with bare hands.

Batteries

The electrolyte present in the batteries is acid. Do not let the electrolyte come in contact with the tissues.

Always wear protective goggles when acting on the batteries. Wash hands thoroughly after touching the batteries or electric connectors. Use of protective gloves is recommended.

Prevention of fires and explosions



All fuels, most lubricants and certain coolant mixtures are flammable.

Flammable fluids that come in contact with hot parts can cause fire, leading to considerable personal damage/injury.

Do not leave flammable material on the vehicle unless it is strictly necessary for its operation.

Store fuels and lubricants in suitable containers, marked specifically, and kept out of reach of unauthorised persons. Store greasy rags or any flammable materials in protective containers. Do not smoke in areas provided for storage of flammable material.

Do not use the vehicle in the vicinity of fire or naked flames.

Do not carry out welding operations near piping or tanks containing flammable fluids. Before carrying out these operations, drain out the piping and tanks and clean all parts thoroughly with non flammable solvents.

Bare electric wires can cause fires or explosions. Check the electrical system daily. Repair or replace damaged wires before starting up the vehicle.

Leakage of flammable liquid from the systems on board can cause fire or explosions. Check all the piping and their supports daily. Repair or replace damaged hydraulic piping. Replace damaged fuel piping.

Take utmost care while refuelling. Do not smoke while refuelling. Do not refuel in the vicinity of sparks or naked flames. Always switch off the engine before

refuelling. Do not carry out refuelling operations in closed poorly ventilated places.

The batteries can produce explosive gases. Do not smoke or use naked flames in the vicinity of the batteries.

Connecting the poles in short circuit can cause the battery to explode. Do not place metallic objects on the surface of the batteries. Do not connect the batteries differently from the method described in this Manual.

Extinguisher

It is advisable to provide the vehicle with an extinguisher. Learn to use the extinguisher and follow the Manufacturer's instructions. Carry out regular maintenance and periodic replacement of the extinguisher.

Ether

Ether is extremely flammable. If it is used for making it easier to start up the engine in cold climates or for any other purpose, adopt the following precautions.

Use ether in the open or in well ventilated areas.

Do not smoke while using ether. Do not use ether in the presence of naked flames, sparks or electrostatic discharges.

Do not place ether cylinders in the operator's cab or in areas where workers are present. Do not expose ether cylinders for long periods to direct sunlight or temperatures exceeding 50°C. Do not place ether cylinders near naked flames, sparks or electrostatic discharges.

Dispose of ether cylinders in accordance with the regulatory standards in force. Do not damage ether cylinders. Keep ether cylinders out of reach of unauthorised persons.

Do not spray ether in an engine if the latter is fitted with thermal devices to facilitate start up in cold climates.

Piping

Do not bend or damage the high pressure piping. Do not install bent or damaged piping on the vehicle.

Repair or replace damaged piping promptly. Leakage can cause fire or explosions. Contact your Dealer for original spare parts and repairs.

Make sure the piping is installed correctly to prevent vibrations, rubbing or excessive heat from affecting the duration.

Information regarding AdBlue

AdBlue is a water-soluble non-flammable, non-toxic, colourless, odourless liquid. It may be referred to as "urea" or "DEF" (Diesel Exhaust Fluid).

If AdBlue comes in contact with painted surfaces or aluminium, wash the areas concerned immediately with water.

Do not mix AdBlue with any additive. Mixing additives with AdBlue can cause serious faults in the plant for post-treatment of exhaust gases.

Any impurity present in AdBlue can cause malfunctioning of the engine and of the exhaust gases post treatment system. Make sure the AdBlue is free of impurities. Do not reuse the AdBlue extracted from the system.

AdBlue and high temperatures

The chemical composition of AdBlue can change if exposed to temperatures exceeding 50° C, releasing ammonia vapours.

Ammonia vapours are highly toxic and corrosive. Ammonia vapours have a pungent smell, and irritate:

- the skin;
- the airways;
- the eyes.

Do not open the AdBlue tank or any part of its supply circuit while the liquid is hot.

Strictly avoid inhaling ammonia vapours or contact with the eyes and skin.

In case of contact with any part of the body, rinse immediately with water for at least 15 minutes and see a doctor immediately.

AdBlue and low temperatures

AdBlue freezes at temperatures below -11° C. However, it is possible to use the vehicle below -11° C.

AdBlue crystals are mainly formed in the tubes between the engine and silencer. Wash with water to remove these crystals.

Storage and disposal

To store AdBlue, use only containers made of one or more of the following materials:

- Cr-Ni steel according to standard DIN EN 10088-1 /2 /3;
- Mo-Cr-Ni steel according to standard DIN EN 10088-1 /2 /3;
- Polypropylene;
- Polyethylene.

Do not use containers made of the following materials:

- Aluminium
- Copper
- Copper alloys
- Non-alloy carbon steels
- Galvanised steels.

AdBlue can corrode these materials and cause severe damage to the exhaust gases post-treatment system.

Dispose of AdBlue in accordance with the standards in force in the country in which the vehicle is used.

For drive units satisfying the STAGE IV anti-pollution standards, in order to protect the AdBlue purification system, wait at least 5 minutes after the I.C. engine is switched off, before acting on the main electric circuit to disconnect it.

Regeneration



ATTENTION

After a predefined period of use or use which affects the working, the filters for scrubbing fine dust emissions require regeneration.

This eventuality is established by the engine diagnostics control unit which sends a specific signal to the multi-function panel in the cab.



As indicated by the warning, the vehicle must be brought to the rest position with the boom retracted and lowered, stabilised, in idle gear, parking brake applied.

Press the button on the top RH of the alarm screen to access the alarms page concerned displaying the specific regeneration activation button.

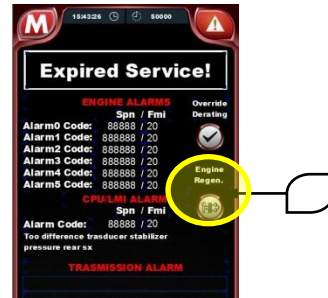

Once regeneration is active lasting 30-40 minutes, all movements of the machine are inhibited.



ATTENTION

During the regeneration, temperatures to the order of 600°C is reached at the end of the exhaust pipe.

Before activating the regeneration procedures, the operator **must** check the area around the machine, if flammable material is present within a range of 5 metres, and if it is impossible to limit operators from approaching the area, the vehicle must be moved to an isolated area to avoid accidental fires or burns.

Accident prevention in case of thunderstorms with lightning

Never try to climb on or get down from the vehicle if lightning strikes in the vicinity.

The operator in the cab must stay inside until the thunderstorm and lightning is over.

If on the ground during a thunderstorm with lightning, the operator must move away from the vehicle and keep at a safe distance.

Spare parts and tooling

The Certificate of Conformity implies the Manufacturer's responsibility only for vehicles without modifications made by the user or by third parties, and only equipped with original, approved spare parts and accessories.

Use only original components for vehicle maintenance.

Using components which are not genuine can affect the working of the machinery and its life.

Using spare parts that are not genuine can invalidate the warranty on the vehicle, and induce the Manufacturer to withdraw the certificate of conformity.



ATTENTION

Use of attachments or accessories not approved by the Manufacturer can cause injury or even death.

Before installing an accessory on the vehicle, check to make sure it has been approved by the Manufacturer and the relative load charts are present in the lift truck software.

In case of doubt regarding the compatibility of an accessory with the vehicle, contact your dealer.

Make sure all the guards on the vehicle and on the accessory are fitted in place.

During the maintenance of the accessories, pay special attention to the sharp and hot parts, and parts which can crush limbs.

Before using the vehicle



ATTENTION

Operators using the vehicle must be trained and must be familiar with all its working aspects. The operator must obtain a license or certificate if required by the regulatory standards in force. If the vehicle is used on public roads, a regular driving license is required in accordance with the laws in force.

The operators must familiarise themselves with the work site or place in which the vehicle is to be used. The entire area must be inspected, with special attention to:

- Availability of clearance for operations on the ground as well as overhead;
- Presence of raised obstacles;
- Presence of electricity lines;
- Presence of steam or compressed air ducts;
- Stability and capacity of the ground to support the loads, with special attention to any areas with backfill.

Drive around obstacles along the path without trying to drive over these.

Keep at a safe distance of at least 10m between the electricity lines and the vehicle or any accessory attached to it.

Make sure the capacity of the ground to support loads is suitable for the weight of the vehicle, the accessory fitted and the load to be handled.

Check the condition of the tyres and the inflation pressure.

Before using the I.C. engine check the level of all the fluids: engine oil, transmission oil, hydraulic fluid, coolant.

Before starting up the engine, make sure there is no one under the vehicle, on top or within its operating area. Fasten the seat belt.

Make sure all the hoods are closed and all guards are installed correctly on the vehicle.

Always shut the cab door. Lock the windows open or closed. Clean all windows to ensure perfect visibility.

Adjust the seat so that the pedals can be pressed completely while sitting correctly. Adjust the steering

column inclination to ensure a comfortable posture and easy access to all the controls.

Check the condition of the seat belt and fixing points. Replace all visibly damaged and worn parts. Replace the entire safety belt after 3 years irrespective of wear. Do not use extensions.

Make sure the lighting on board is adequate for the working conditions, and that all the lights are working correctly.

Check to make sure the buzzer, signalling lights and all the alarm devices work correctly.

Noise and vibrations

Noise level

The noise level ensured in the outside environment is equal to or less than 106 dB(A), depending on the drive unit applied. The measurement has been done according to Directive 2000/14/EC successively amended by Directive 2005/88/EC.

Vibration level

Hands and arms are subjected to an average weighted acceleration level less than 2.5 m/s^2 .

The entire body is subjected to an average weighted acceleration level less than 0.5 m/s^2 .

These levels are measured on a standard machine. The measuring procedure used is described in detail in the following standards:

- ISO 2631-1:1997
- ISO 5349-1:2001
- SAE J1166

Protection for the operator

Check the protection devices daily for damaged structures. It is forbidden to use the machine with damaged protection devices.

Improper use of the machine can be hazardous for the operator even if protection devices in perfect condition are used. Therefore, it is advisable to follow the operating procedures described in the following sections of this Manual.

Roll-Over Protective Structure (ROPS), Falling Objects Protective Structure (FOPS)



The ROPS/FOPS certification label is applied in the upper part inside the cab.

The ROPS/FOPS structure is specially designed, tested and certified for the machine. Any alteration of the structure can weaken and put the operator at risk.

The protection offered by ROPS/FOPS structures will be affected in case of structural damage.

Avoid structural repair or modification of the ROPS/FOPS structure. These operations will make the structure different from the original, and cause invalidation of the certification.

SECTION ON PRODUCT INFORMATION

TECHNICAL SPECIFICATIONS

ENGINE: DEUTZ stage IV / Tier 4

<i>ENGINE SERIES</i>	TCD 3.6 L4 - EU stage IV / US EPA Tier 4
<i>THERMODYNAMIC CYCLE</i>	Diesel 4 strokes
<i>ARCHITECTURE</i>	4 cylinders in line
<i>VALVES</i>	16 valves
<i>POWER SUPPLY</i>	Turbocompressed with intercooler
<i>DISPLACEMENT</i>	3,621 cc
<i>CYLINDER BORE</i>	98 mm
<i>STROKE</i>	120 mm
<i>COOLING</i>	With liquid
<i>MAXIMUM POWER</i> <i>2200 rpm</i>	100 KW / 134 HP
<i>MAXIMUM TORQUE</i> <i>1600 rpm</i>	500 Nm
<i>RATED SPEED AT MINIMUM</i>	850 rpm

TRANSMISSION

<i>TYPE</i>	hydrostatic with Rexroth electronic control
<i>MAXIMUM PRESSURE</i>	450 bar
<i>No. OF FORWARD GEARS</i>	2
<i>No. OF REVERSE GEARS</i>	2
<i>GEAR REVERSAL</i>	Electro-hydraulic

HYDRAULIC SYSTEM

<i>PUMP</i>	with variable displacement pistons
<i>CAPACITY at 2200 rpm</i>	92.4 l/min
<i>PRESSURE</i>	350 bar
<i>DISPLACEMENT</i>	42 cc

ELECTRICAL SYSTEM

<i>MASS</i>	negative
<i>BATTERIES</i>	2 12 V – 150 A batteries
<i>ALTERNATOR</i>	28V 80A
<i>START-UP</i>	24 V

AXLES

<i>FRONT AXLE</i>	Steering and levelling
<i>REAR AXLE</i>	Steering and tilting
<i>WHEEL HUB REDUCERS</i>	Epicyclic
<i>TYRES</i>	18 R 22.5

BRAKES

<i>TYPE</i>	Multidisk in oil bath
<i>SERVICE BRAKE</i>	Pedal-operated servo-assisted, action on front and rear wheels
<i>PARKING BRAKE</i>	Hydraulic negative action on front axle

PERFORMANCES

<i>MAXIMUM SPEED</i>	40 km/h
<i>STANDARD LIFTING HEIGHT</i>	19,20 m
<i>SLOPE THAT CAN BE COVERED</i>	44 %
<i>MAXIMUM RATED CAPACITY</i>	6000 kg

MASSES

<i>MASS IN THE ORDER OF MOVEMENT (without accessory)</i>	14500 kg
<i>MASS DISTRIBUTION ON FRONT AXLE</i>	6000 kg
<i>MASS DISTRIBUTION ON REAR AXLE</i>	8500 kg

DIMENSIONS

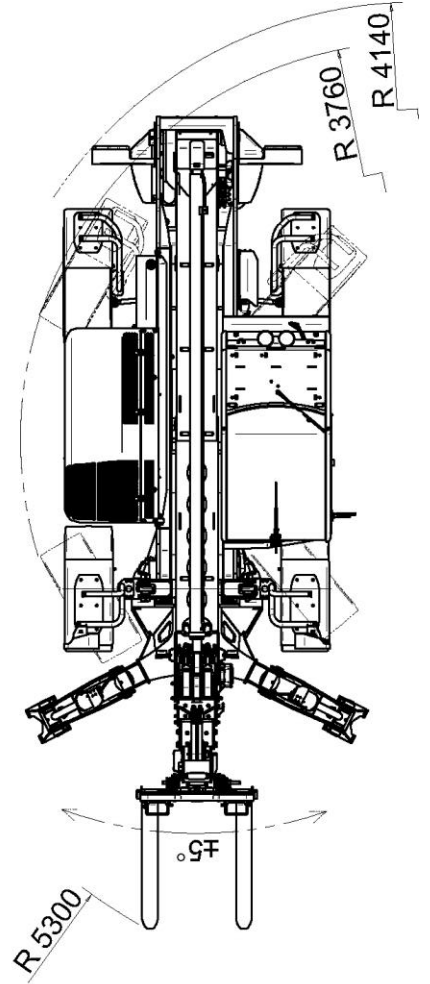
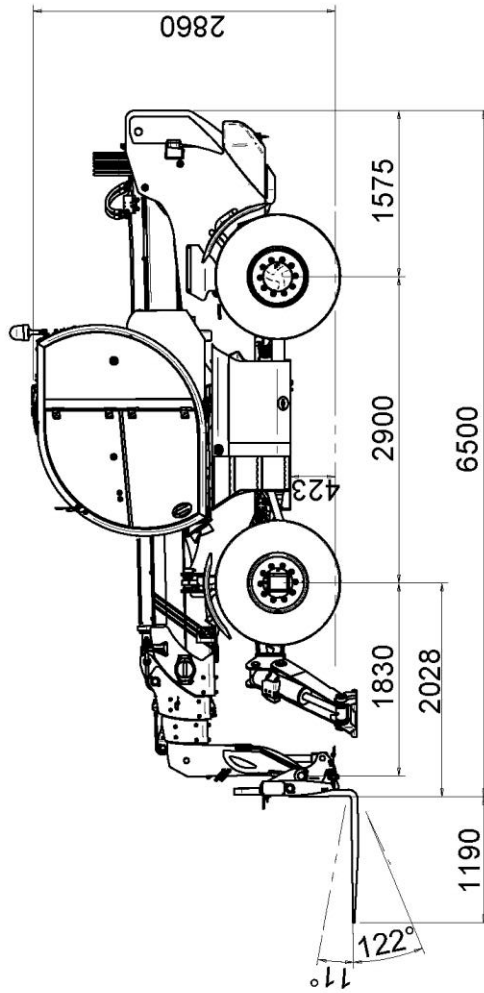
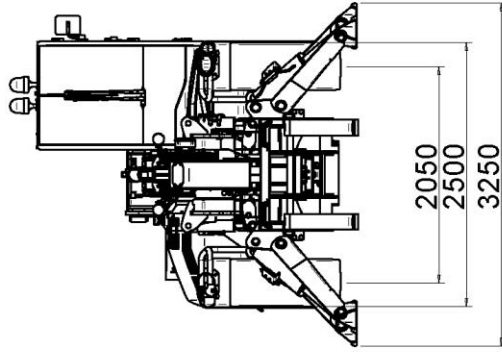

LOAD CHARTS

Standard equipment: fork carriage capacity 6000 kg

Forklift truck on tyres

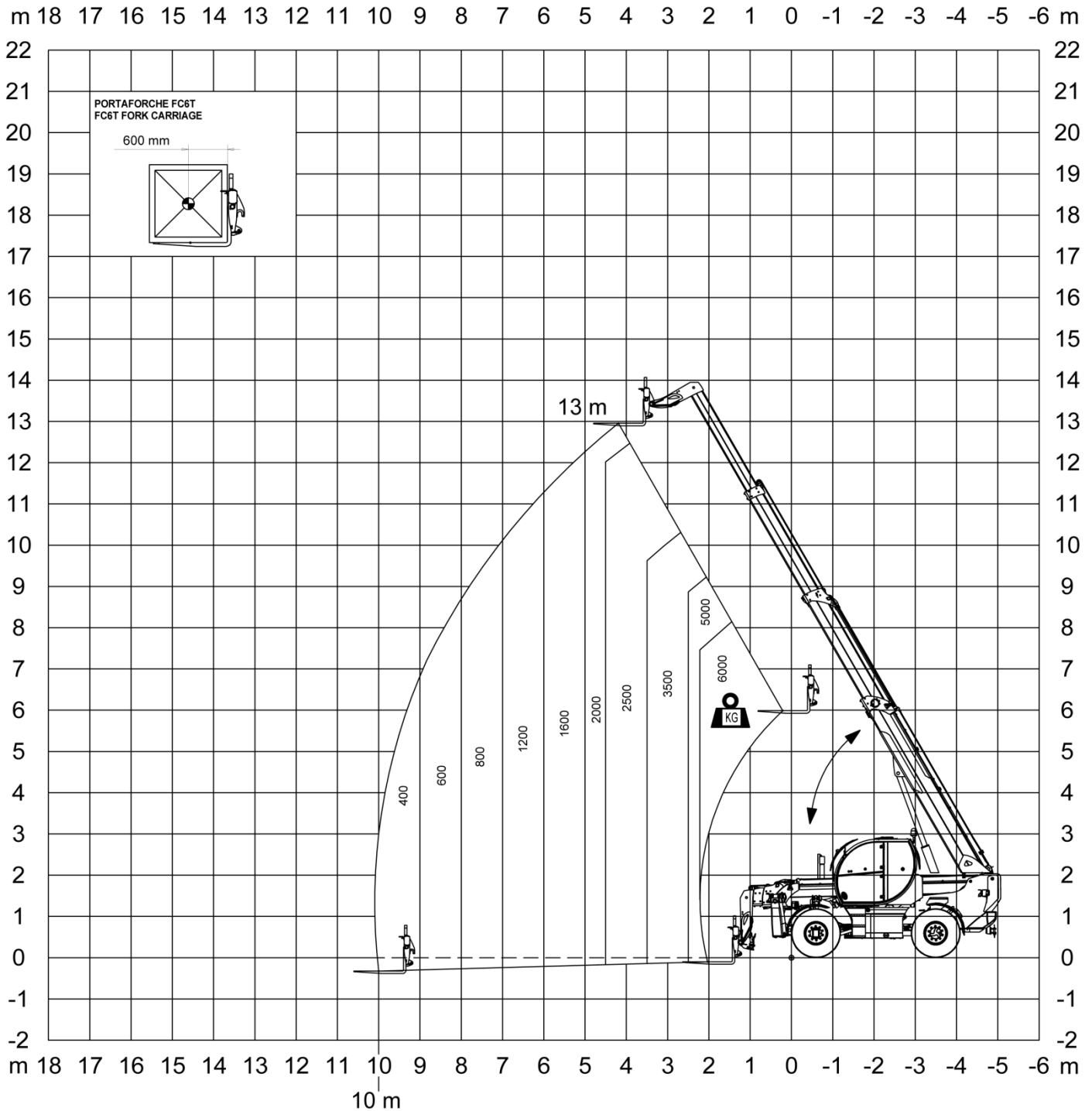

Forklift truck on stabilisers

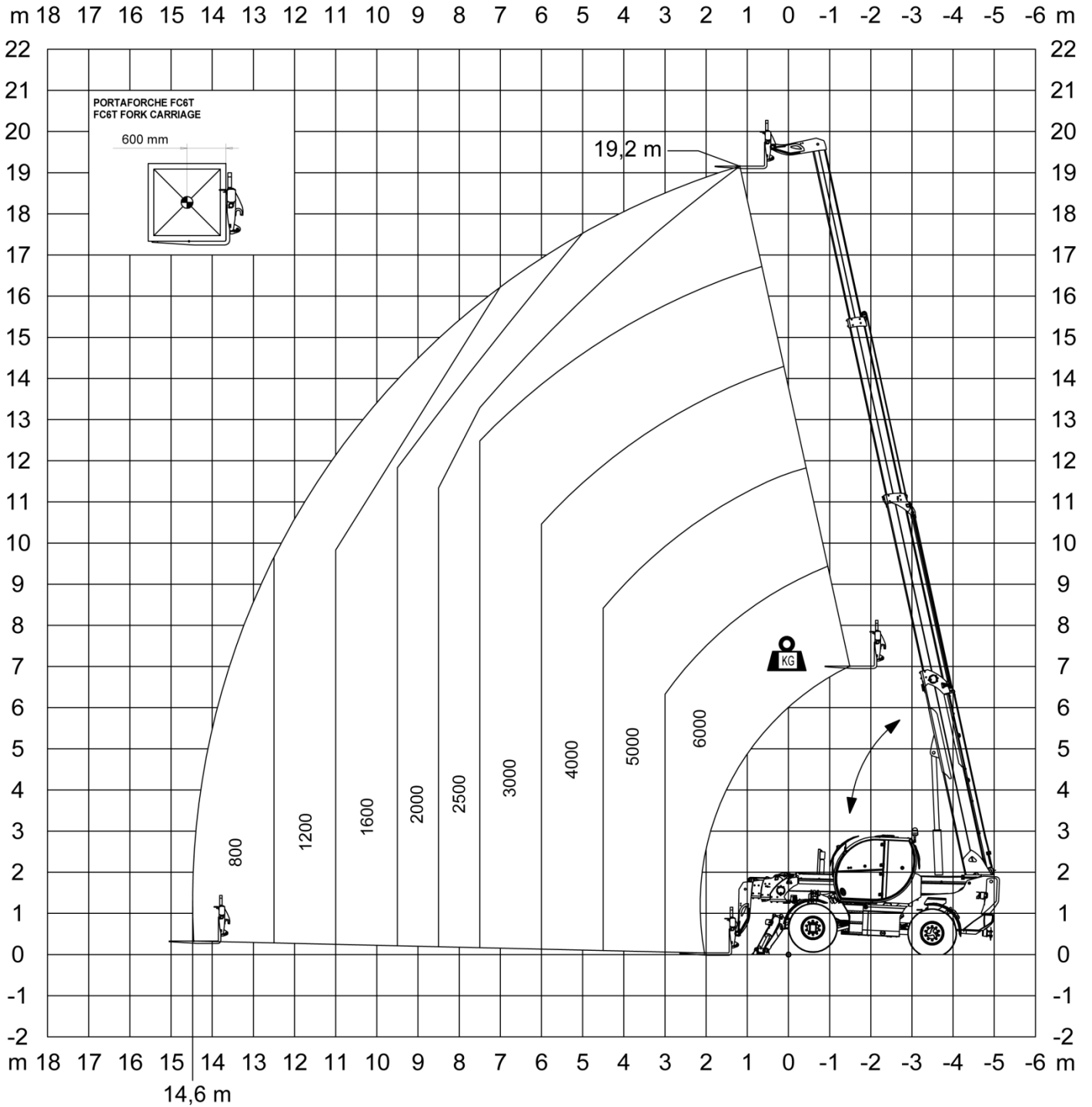

FEATURES OF THE VEHICLE

Front Headlamps

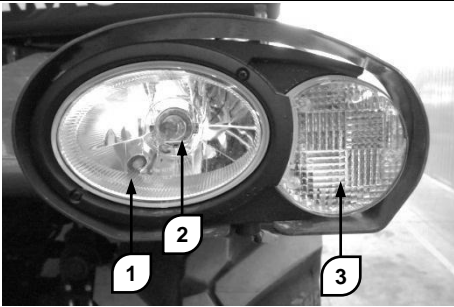

The headlamps unit consists of the following lights:

- Position lights **[1]**: always On when the vehicle's electrical system is powered;
- Low beams/high beams **[2]**: low beams always On when the I.C. engine is started up; high beams can be selected by means of the lights switch;
- Direction indicators **[3]**: can be operated by means of the lever under the steering wheel.

Rear headlamps

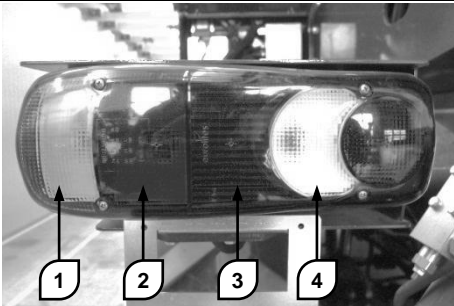

The rear headlamps unit consists of the following lights:

- Direction indicators **[1]**: activated by the lever under the steering wheel or by the Hazard button;
- Stop lights **[2]**: activated by pressing the brake pedal;
- Position lights **[3]**: activated when the vehicle's electrical system is powered;
- Reversing lights **[4]**: activated simultaneously when reversing is activated.

To facilitate operation at the workplace and to limit the projecting parts of the machine, both rear light units can be rotated upwards, removing the butterfly screw, lifting the light unit towards the vehicle chassis and block the entire assembly with the same butterfly screw.

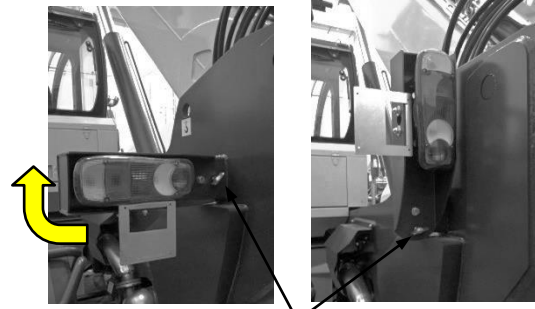

Butterfly screw

Work lights and emergency lights

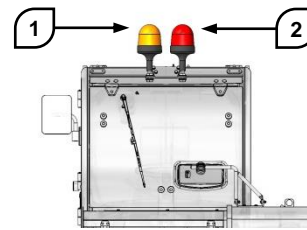

The orange **work light [1]** can be switched on during the working of the machine to indicate movement.

The red **emergency light [2]** lights up automatically when the work overload is reached.

Rear-view mirrors

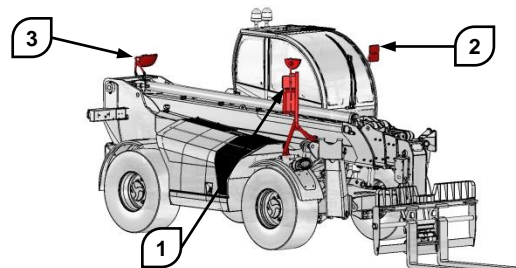

The machine is provided with a series of five rearview mirrors as standard: three to the RH of the chassis **[1]**, one to the LH of the cab **[2]** and one in the rear part of the machine chassis **[3]**.

Adjust the rearview mirrors before starting up the vehicle to provide the operator maximum visibility of the surrounding work area.

Quick-fit of the accessory

The vehicle can be ordered with two types of quick-fit coupling for the accessory.

Type "I" coupling



The type "I", coupling, with Magni Telescopic Handlers patent, is designed to be more rigid, more compact, easy to fit, in comparison with those of competitors and is designed solely for accessories designed and constructed by Magni Telescopic Handlers with similar coupling.

"U" type coupling



The "U" type coupling ensures greater compatibility with different types of accessories: It can, in fact, be fitted with accessories designed and constructed by Magni Telescopic Handlers with similar coupling just as it can also be fitted with accessories designed and constructed by other manufacturers (e.g. Manitou Costruzioni Industriali), after checking the conformity and installation of suitable devices by Magni Telescopic Handlers.

Shear pin housing (standard)

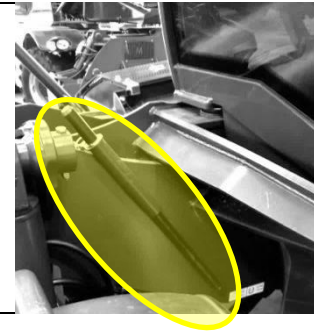

The housing of the shear pin for quick-fit of the accessory is present in the front part of the vehicle chassis.

The shear pin must also be present on the vehicle so as to be available when required.

Always fit the shear pin in its housing when not in use.

If placed in unsuitable places, the shear pin may get jammed between the moving parts of the vehicle, causing severe damage.

Anchoring points

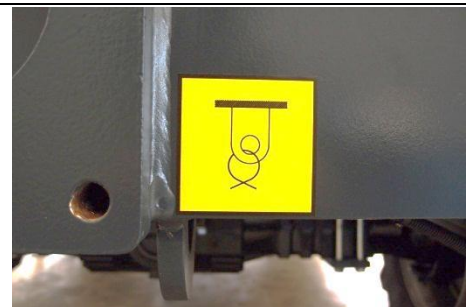

The vehicle is provided with four anchoring points, in the front part of the chassis and in the rear part, all marked by a yellow sticker as shown above.

Unless otherwise indicated in this Manual, never fix lifting or anchoring devices to other parts of the vehicle.

Tow hook

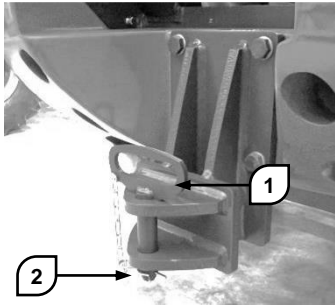

ATTENTION

If not used correctly, the tow hook can cause accidents or material damage.

The towing operations must always be carried out by personnel appropriately trained in compliance with the laws in force.

The vehicle is provided with a tow hook positioned in the rear part of the chassis.

Do not connect towing devices other than the tow hook as anchoring points to parts of the vehicle.

Always lock pin [1] using the split pin [2] to prevent it coming loose accidentally.

Additional work lights (optional)

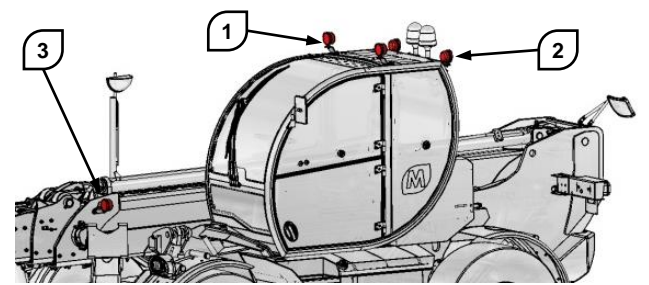

The vehicle can be fitted with additional lights to light up the work area. The additional work lights are divided into three groups:

- Front work lights [1], fitted on the cab and facing the front;
- Rear work lights [2], fitted on the cab and facing the back;
- Boom work lights [3], fitted on the telescopic boom and facing the accessory

Setup for countries with cold climate (optional)

The vehicle can be ordered with special equipment for countries with severe cold climates. The Nordic equipment is designed to allow safe easy use in environments characterised by poor natural lighting and particularly low temperatures.

The main modifications and additions included in the Nordic equipment are:

- Fluids and lubricants suitable for low temperatures;
- 220V socket in the cab;
- Additional work lights;
- Toolbox;
- Battery disconnect switch above the engine compartment;
- Partly screened radiator grille.

Avoid using a vehicle with Nordic setup with environmental temperatures higher than +10° C. In such conditions, the lubricants and the capacity of the radiator to dissipate heat may not be suitable, and may cause serious damage to the engine.

If the machine is to be used with Nordic setup outside normal operating conditions, consult your dealer for the necessary modifications.

OPERATION

Multiple function Display



ATTENTION

Using the multiple function display while driving can cause serious accidents.

It is advisable to limit the use of the display while driving to the minimum possible extent to allow prompt identification and avoid obstacles along the vehicle route.

This Chapter contains information regarding the methods of use of the display and an overview of the information provided for the operator.

For functions connected to the buttons present in the various pages, consult the operating techniques described in the successive chapters.

The touch-screen display is situated inside the driver's cab, on the RH side, in front of the RH joystick.

The information and controls provided for the operator by the multiple function display are divided into a number of pages. The pages are, in turn, divided into four groups:

- Control and command pages;
- On board diagnostics pages;
- Password pages;
- Alarms page.

The pages concerning the working of the machine are (in the order of appearance):

- Accessory confirmation page;
- Main page;
- Stabilisers page;
- Load check page;
- Controls page;
- Limits page.

Browsing through the pages

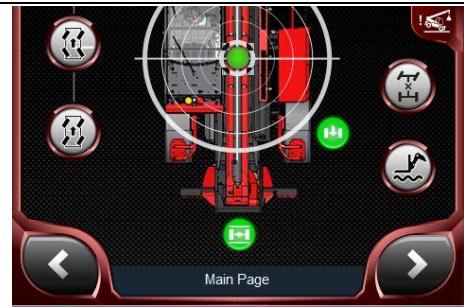

Each page is divided into a number of sections. The current section is highlighted on the display in electric blue, as shown above.

Each section may contain one or more buttons. Each button when pressed will take on a number of configurations, distinguished by the colour:

- Button not pressed and not selected
- Button not pressed and selected
- Button pressed and not selected
- Button pressed and selected
- Button not active

A button is not active when it belongs to a sector different from the current one or cannot be selected for the forklift truck model being used.

During the working of the machine the page most relevant to the current action is selected automatically. In particular:

- When the forward or reverse gear is engaged, the display automatically shows the main page;
- When the stabilizers are activated automatically by means of the switches, the stabilizers page is automatically displayed;
- When hydraulic movements of the telescopic boom are performed, the displays automatically shows the load control page.

In case of two simultaneous actions, like the movement of the forklift truck on wheels and the movement of the boom, the load control page is given priority.

It is possible to browse through the pages of the display manually. To do so, use the four arrows present at the corners of the screen:

Moving between the control/command pages and the on board diagnostics pages

Access to the alarms page

Moving to the next page

Return to the previous page

There are two ways for browsing manually among the pages and pressing the buttons present in these.

Browsing using the touchscreen

Pressing on any button on the screen will activate or deactivate the connected function.

Browsing using the controller

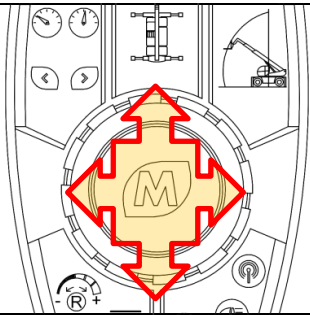

To the RH of the driver's seat there is a joypad consisting of a controller and display controls buttons. These allow the operator to interact with the display without using the touchscreen. The following commands can be given using the joypad:

- Press one of the five buttons;
- Move the controller forwards or backwards;
- Move the controller to the RH or LH;
- Rotate the controller around its axis;
- Press the controller downwards.

Move the controller forwards or backwards to move between the sections of a page. The selected sector of the page is shown in blue.

Rotate the joystick clockwise or counter-clockwise to select the buttons in the current section of the page.

Press the joystick down to press the button selected on the display.

The five buttons arranged around the joystick correspond to the following functions:

Displays the main page

Displays the stabilizers page

Displays the load control page

Displays hydraulic movements limits and speeds page (if activated by software)

Displays the commands page

Adjusting the control panel intensity

To adjust the intensity of the control panel backlighting press the controller button showing the stabilisers for 3 seconds until the display shows the icon indicating the luminosity percentage.

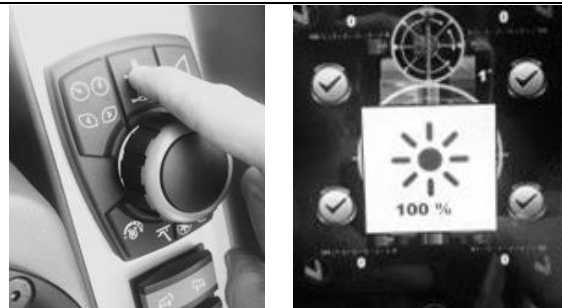

Keeping the button pressed, turn the controller knob clockwise to increase the panel luminosity or counter-clockwise to reduce it.



Release the controller button after obtaining the required luminosity.

Accessory confirmation page

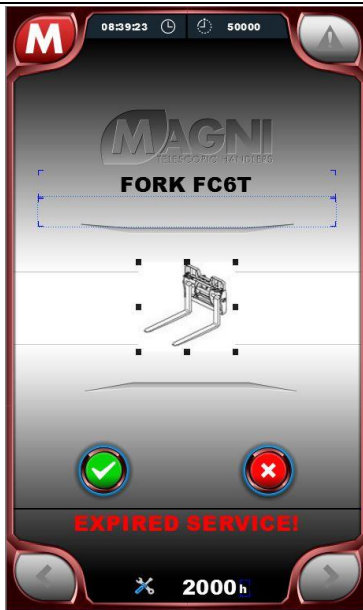

This page is displayed every time the sensor at the head of the telescopic boom detects a new accessory. This page cannot be selected manually.

Below the **Magni**, logo, the name of the accessory identified by the control system is shown in the centre of the screen. A graphic representation for rapid identification is also provided.

Identification of the accessory fitted or absence of the accessory can be confirmed in this screen page by pressing on the GREEN icon.

In the case of incorrect identification of the accessory, press the RED button for lack of confirmation; it is however possible to use the vehicle, but the functions and load capacity will be limited for safety reasons; **contact the Magni TH Assistance Service.**

The number of hours before the next scheduled maintenance is shown at the bottom of the page.

Main page

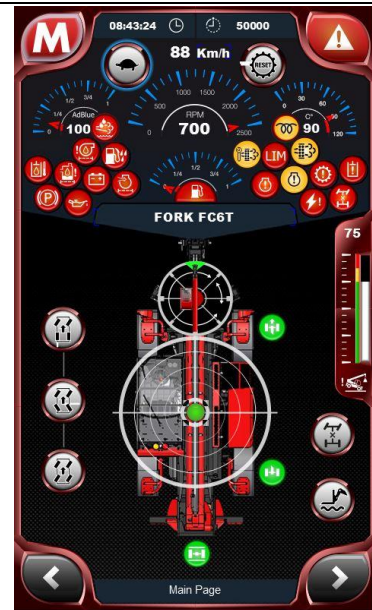

The main page contains main information regarding the machine in the driving configuration on tyres.

For all the models the display shows, at the top: the daily time and working hours of the forklift truck, the speed selection button and the reset button.



Speed

The two-speed hydrostatic transmission works according to two modes:

- "Tortoise" mode;
- "Hare" mode.

The buttons for selection of these modes are present at the top in the main page:



-  Tortoise → hare button
-  Hare → tortoise button
-  Reset button

The hare and tortoise buttons occupy the same position on the display. The current operating mode is highlighted by the symbol present on the button.

In “tortoise” mode, the transmission allows the vehicle to move at low speed. Use this mode for precision movements and to move the load.

In “hare” mode the transmission uses both speeds and makes it possible to reach maximum speed. Use this mode for travelling on roads or for rapid movements in the work area.

To switch from “hare” mode to “tortoise” mode, press the hare → tortoise button. To switch from “tortoise” mode to “hare” mode, press the tortoise → hare button.

If necessary, it is possible to change forcibly from one mode to the other by pressing the “reset” button.

Graduated indicators







Depending on the type of drive unit used, the digital indicators show the engine oil pressure, the engine rpm, the coolant temperature for Stage 3A as shown in the graph below,



















the AdBlue liquid level, the engine rpm and coolant temperature for Stage 4 as shown in the graph below



Indicator lights

-  Fuel tank in reserve
-  Diesel engine oil pressure alarm
-  Diesel engine temperature alarm
-  Hydraulic motor oil filter clogging alarm
-  Water/fuel separator filter clogging alarm
-  SCR Alarm
-  Hydraulic fluid temperature alarm

-  Hydraulic fluid tank filter clogging alarm
-  Batteries flat alarm
-  Diesel engine suction filter clogging alarm
-  AdBlue tank in reserve (present on models with urea tank)
-  Generic diesel engine alarm
-  Serious diesel engine alarm
-  Generic transmission alarm
-  Generic hydraulic system alarm
-  Parking brake applied
-  Service brake system alarm
-  Generic electrical system alarm
-  Telescopic boom shock absorber activated
-  AdBlue level alarm for TIER4 drive unit
-  AdBlue level alarm for TIER4 drive unit
-  Front wheels alignment
-  Rear wheels alignment
-  Rear axle block applied

Front axle shift indicator



In the centre of the MAIN, LOAD, STABILISERS and LIMITS page there is an indicator for centring the movement of the front axle: when the axle is perfectly centred, the green indicator in the upper central part lights up; otherwise it is OFF and grey.

Before every movement on wheels, check to ensure that the front axle is aligned perfectly with the longitudinal axle of the forklift truck.

Vehicle levelling indicator

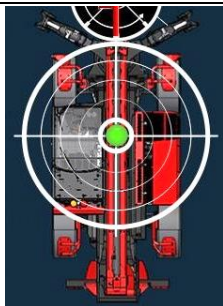

Vehicle levelling means the inclination of the chassis with respect to an ideal perfectly horizontal flat surface. Vehicle levelling is not the inclination of the chassis in relation to the ground.

A circular green marker in the centre of the page provides graphic indication of the vehicle levelling. In case of imbalance, the marker moves in the direction of the vehicle's centre of gravity. In the example in the Figure, the marker is in the centre, so the vehicle is perfectly level. When the vehicle leaves this range by 3° the marker changes to flashing yellow.

- [1] button for self-levelling on stabilisers,
- [2] operating hydraulic pressure measured for stabiliser,
- [3] stabiliser position,
- [4] movement enabling,
- [5] stabiliser movement graphic indication,
- [6] radio control activation button.

Stabilisers page



The stabilisers page contains information regarding the configuration of the stabilisers, and certain buttons to control the working:

Load check page



The load check page contains information regarding the configuration of the telescopic boom and accessory fitted.

Configuration of boom



The section at the top of the load check page contains information regarding the boom configuration. The data shown in the graph above and organised from LH to RH, top to bottom, are:

- Telescopic boom extension length;
- Height of centre of gravity of accessory from ground;
- Layout for rapid interpretation of information;
- Telescopic boom angle in relation to the horizontal;
- Distance of boom head from front wheel;
- Maximum permitted load for current configuration of the boom;
- Actual load.

Interactive load chart

The interactive load chart is seen at the centre of the display. To the top LH a schematic drawing of the accessory detected is displayed for rapid identification.

The vehicle control system automatically selects the appropriate load chart on the basis of the three parameters measured:

- Type of accessory fitted at the top of the boom, detected automatically by means of the transponder;
- Resting on the ground and percentage extension of the stabilisers;

The position of the load on the chart is identified by the following icon:

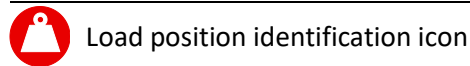

Load position identification icon

The icon moves on the chart in relation to the position of the boom.

Load percentage

To the RH on the page a graduated indicator displays the ratio, expressed in percentage, of the load acting on the accessory and the maximum permitted load.

The load percentage indicator is present in all the control and command pages on the RH of the monitor.

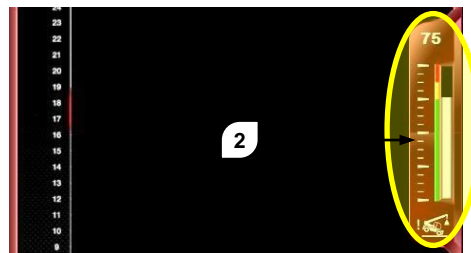

The load percentage indicator in combination with the load chart provides complete clear information regarding the operating conditions of the vehicle.

Limits page



The limits page contains the controls for the hydraulic movements of the telescopic boom. The control functions are as follows:

- Boom extension and lifting limit;
- Adjustment of the speed of the hydraulic movements.

The methods for using these functions is described in the relevant chapters in the “Controls” section.

Controls page



The controls page contains information and controls regarding the cab conditioning system and control

buttons for the work lights, boom suspension and radio control.

Air conditioning



The commands of the cab air conditioning system are present in the upper part of the commands page.

Press button [1] to activate or deactivate the air conditioning.

To adjust the temperature of the air coming out of the air vents use the + and - buttons under the air temperature indicator [3].

To adjust the air flow from the vents use the + and - buttons under the air flow rate indicator [4].

In case of contamination of the outside air, recirculation of the internal air can be activated. To activate or deactivate internal air recirculation press button [2].

The indicators do not express the temperature or flow rate values but only reference numeric values.

Work lights

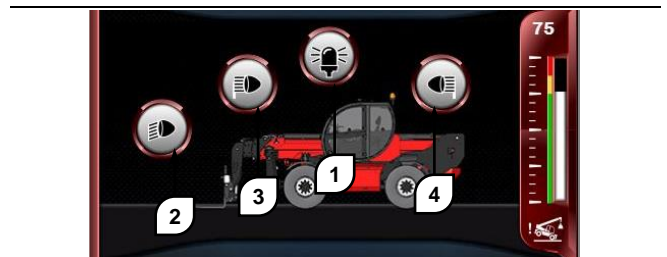

Button [1] activates the orange beacon that indicates that the vehicle is in motion.

Buttons [2], [3] and [4] activate the lights at the top of the boom, those on the front of the cab and those at the rear of the cab, respectively.

Built-in traction release



Press this button to deactivate the traction at the rear axle wheels.

Telescopic boom suspension (optional)



This button is present if the optional is present on the forklift truck being used.

The telescopic boom suspension is designed for operating the vehicle on uneven ground with loads raised.

To use this function the following conditions must be respected:

- vehicle on wheels;
- telescopic boom height from the ground less than 3 meters.

To activate/deactivate the telescopic boom suspension, press the button in the commands page shown above. Wait for the relevant indicator to light up or be switched off in the main page of the display to confirm the required selection.



The boom suspension only works in the presence of the afore-mentioned conditions: if said requirements are not satisfied during a movement, the function is automatically disabled; if, with the forklift truck moving, the parameters required fall within the envisaged limits, the boom suspension is automatically reactivated.

When the truck stops, the function is deactivated; to reactivate it repeat the procedure described above.

Checking the engine rpm



The button indicated is used to activate or deactivate the engine speed electronic control function: if selected, as soon as a hydraulic movement is imparted to a forklift truck component, the engine automatically increases the speed to provide force to the services pump and consequently facilitate the movement imparted.

Activation of radio control



To operate the truck externally using radio control the receiver connection present on the vehicle must be activated by pressing the button shown above.

To use the radio control (OPTIONAL) refer to the relevant Use and Maintenance Manual.

24V socket (OPTIONAL)



Press this button to activate the power socket (optional) present at the top of the boom for supplying current to the accessories that may be fitted.

Auxiliary continuous function



This selection **1** makes it possible to activate, for a certain accessory, the continuous movement of one of its element such as a mixer bucket, adjusting the operating speed by means of the buttons concerned, **2** and **3**.

Value **4** is the flow % as regards the maximum flow rate.

Cooling fan inversion function



This selection makes it possible to invert the direction of fan rotation, for forklift trucks equipped with horizontally installed cooling element.

This function makes it possible to blow air outside the engine compartment to clean the aeration surfaces by removing accidental deposits of material potentially harmful for the equipment.

The inversion sequence involves two minutes of air suction and one minute of expulsion at cyclic intervals of 20 seconds of slowing down of the fan speed in order to protect its mechanism.

FEATURES OF THE CAB

Cab door



Open the cab door lock using the key meant for the purpose.

To open the cab door from the outside, pull outer handle **[1]**, then guide the door all the way.

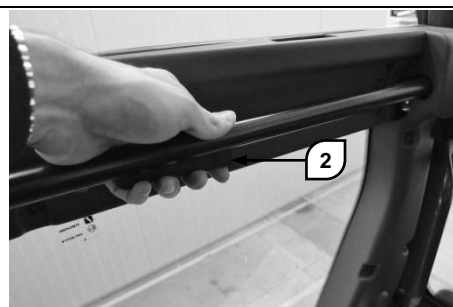

To open the cab door from inside, pull lever **[2]**, then guide the door all the way.

The cab door must be kept closed when the machine is in operation. To allow natural ventilation inside the cab, use the rear window or side window.

Cab window

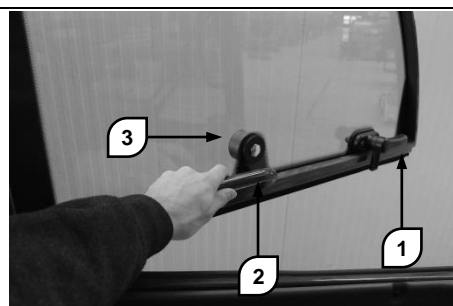

The cab window can be opened to allow natural ventilation.

To open the window, only from inside the cab, turn lever [1] counter-clockwise to unlock it. Push the window outwards, guiding it all the way by holding handle [2]. Push further to fit lock [3] in its seat [4].

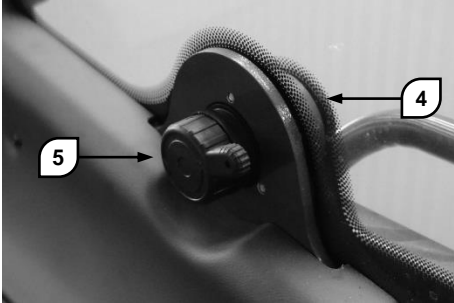

To shut the window, turn lever [5] counter-clockwise to release the limit stop block. Guide the window until it is closed, holding it by handle [2]. Turn lever [1] clockwise and make sure the window is locked in the closed position.

Rear window



The rear window of the cab can be opened to allow natural ventilation. To open the window, only from inside the cab, turn lever [1] counter-clockwise to unlock it. Push the window outwards.

To shut the window, hold lever [1] and pull it inwards. Turn lever [1] clockwise to lock the window shut.

Emergency exit

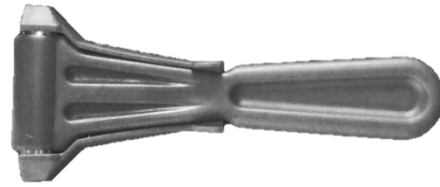

A red hammer is present inside the cab, on the right of the door jamb; it must be used in case of an emergency to break the door and/or window glass to make exit easy for the driver.

Contact your dealer to have the glass replaced.

Seat

The driver's seat is designed in accordance with law to allow a correct posture and prevent the onset of muscular-skeletal illnesses for the driver following prolonged working activities.

Always adjust the seat to suit your physical structure for maximum comfort.

Seat suspension



Turn the grey lever for adjustment of the spring suspension of the seat to adjust the pre-load until the yellow numeric indicator corresponds approximately to the operator's weight.

Longitudinal position of the seat

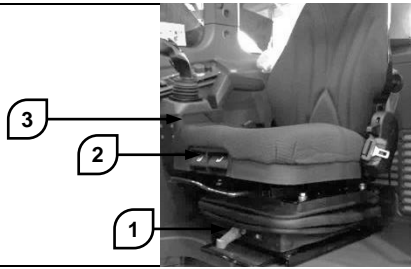

Act on lever [1] to move the entire seat in the longitudinal direction including the RH arm-rest and the relative joystick.

Act on lever [2] to move the seat in the longitudinal direction. Using this lever will keep the arm-rest and the relative controls fixed, moving only the seat and back-rest.

Act on lever [3] to shift the set in relation to the back-rest, keeping the arm-rest and the relative controls fixed

Inclination of the seat



Use the LH lever (remaining seated) in the centre of the seat to change its inclination as required.

Tilting the backrest



Use the lever on the LH side of the backrest to adjust the inclination with respect to the seat.

The adjustment is correct when the operator's back forms a $95^\circ \pm 5^\circ$ angle with the legs when seated properly.

Seat belts

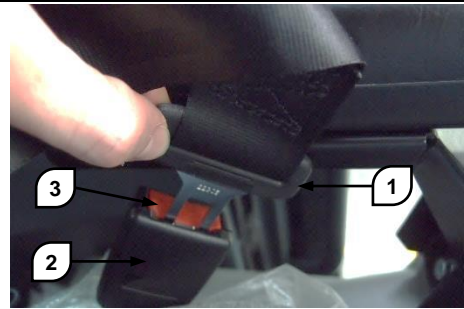

The seat belt is provided with an automatic winding system. The system is blocked automatically if the belt is pulled violently.



ATTENTION

Do not use extensions for the seat belt.

The automatic winder may not work properly, causing accidents, sometimes fatal.

If necessary, consult your dealer to have longer seat belts fitted.

Always check the fabric of the safety belt, the buckle and winder, every time before using the machine.

Replace the seat belt or components found to be worn or damaged.

Fasten the seat belt

Pull the seat belt out of the winder with a slow fluid movement to prevent automatic blocking.

Insert tab [1] in buckle [2], and press till the locking mechanism clicks into place. Check to make sure the tab is locked by pulling gently.

Unfasten the seat belt

Push the red button [3] on the buckle.

Hold the tab with one hand while the seat belt is rewound automatically.

Safety keys container

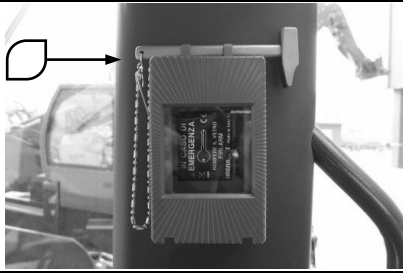

The container for the keys used for disconnecting the safety systems is fitted on the LH jamb inside the driver's cab.

The container contains two keys:

- key for exclusion of the rollover protection safety systems, with metallic grip;
- key for exclusion of the lift platform safety systems (optional), with plastic grip.

For the method for taking and using the keys, see the "safety systems exclusion systems" section.

Air vents



The air vents positioned in front of the driver, behind the seat, and on the LH upright let in air flow into the cab.

Each air vent can be opened and closed, and is used to adjust the direction of the air flow.

Vehicle radio



The vehicle radio is present on the rear covering of the cab behind the operator's head. The speakers are

present between the driver's seat and the rear window.

The radio is included in the standard vehicle supply. However, any other radio can be fitted with dimensions 1-DIN in accordance with standard ISO 7736.

For the working of the radio installed, refer to the Instruction Manual included in the package provided together with the vehicle.

Electric cigarette lighter



The electric cigarette lighter is present in the dashboard to the RH of the driver's seat.

Press the cigarette lighter to block the button to activate it. Wait for the button to click, then remove.



DANGER OF BURNS

Do not touch the metallic parts of the electric cigarette lighter.

The metallic parts of the electric cigarette lighter remain hot for a few minutes after the button is released. Touching these parts can cause burns.

The electric cigarette lighter can be used as a 12V power socket. To use it as a power socket, remove the electric cigarette lighter without pressing it and insert the male cigarette lighter socket supplied with the device to be powered.

220V socket in cab (optional)



ELECTRICITY

The power socket is not provided with circuit breaker devices. In the absence of circuit breakers, contact with high voltage electric current can cause serious burns or even death.

Take all necessary precautions to prevent direct or indirect contact with high voltage electric current.

The power socket is present under the driver's seat, near the cab door.

The power socket can be provided in the cab to power electric and electronic devices that run on 220V AC power supply.

When not in use, disconnect the devices from the power socket and keep them out of the way so as to avoid obstructing the operator's movements.

If electric stoves or appliances with extremely hot parts are used, avoid going near the seat or other potentially flammable parts.

CONTROLS

Steering column

The steering column provides numerous possibilities for adjustment. The position of the steering wheel can be adjusted for height and depth. The correct position depends on individual preferences, but it is advisable to follow the indications given below:

- It must be possible to reach the steering wheel without detaching the shoulders or back from the back rest;
- The arms must be bent at right angles when gripping the steering wheel;
- The joysticks must not obstruct rotation of the steering wheel while driving, in any manner whatsoever;
- The position of the steering wheel must not obstruct the movements of the joysticks, in any manner whatsoever.

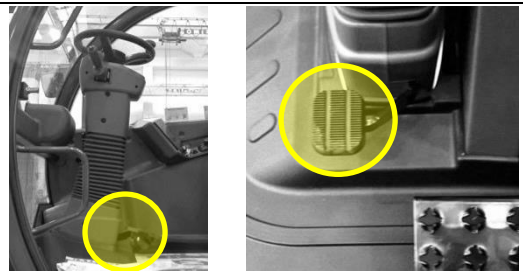

Sit correctly and act on the pedal shown in the photo while at the same time pulling the hand wheel towards you to adjust the angle; after finding the correct angle, release the pedal.

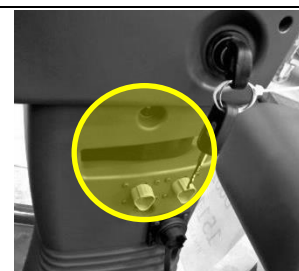

To adjust the depth of the handwheel, act on the telescopic lever of the steering column positioned on the Rh, under the ignition key, pulling it outwards, then adjust the distance: after finding the right distance reposition the locking lever.

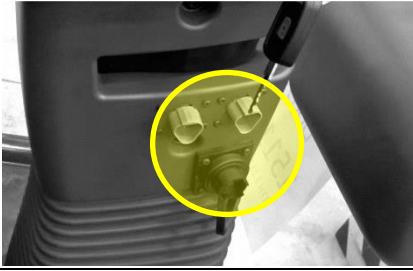

On the RH side, under the lever for adjustment of the depth of the steering column, there are 2 CAN type connectors for control of the diagnostics of the entire machine and 1 LAN type connector for transferring data to the vehicle/software updates.

Ignition switch

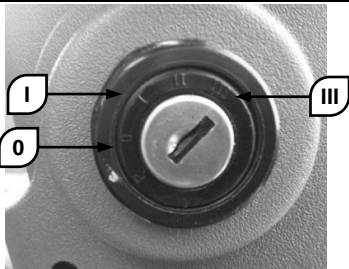

The ignition switch is situated on the steering column, to the RH. The switch has three active positions:

- 0: I.C. engine stop;
- I: main electric contact closure;
- III: Starter motor contact.

Positions P and II of the switch are deactivated.

Lights/windscreen wiper selector



The lever to the LH of the steering wheel controls the direction indicators, work lights switch and windscreen wipers.

Direction indicators

To activate the direction indicators:

- RH: push the lever forwards;
- LH: pull the lever backwards;

The direction indicators are deactivated when the lever is in the central position.

Lights switch

To activate the low beams:

- move the lever down for continuous activation,
- press slightly towards the handwheel to activate flashing of the high beams. The lever will return immediately to the neutral position when released.

Windscreen wipers

The vehicle has three windscreen wipers. The wiper on the rear window is activated separately, while those on the upper window and windshield can only be activated simultaneously.

Controls:

- 0: all wipers deactivated;
- I: activates intermittent movement of the front and upper windscreen wipers;
- II: activates continuous movement of the front and upper windscreen wipers;
- J: activates the rear windscreen wiper.

To active dispensing of the window washer liquid press the crown at the tip of the lever.

Warning buzzer

To use the warning buzzer press the button in the centre at the tip of the lever.

Do not use the warning buzzer in densely populated spaces or where expressly banned by means of signs.

NOTE: the warning buzzer emits a short warning if connected with a radio control (optional).

Parking brake



The switch for engaging/disengaging the parking brake is under the steering wheel.

Press the switch to apply the parking brake. Check to make sure the indicator light in the main page of the multiple functions display lights up.

To deactivate it, sit properly in the seat, start up the engine, check to make sure the reverse gear is in "neutral" then press switch (P) to release the parking brake. Check to make sure the indicator light in the main page of the multiple functions display switches off.

At a speed below 3 km/h, if the driver gets up from the seat, the vehicle stops automatically, and the parking brake is applied.

Emergency lights

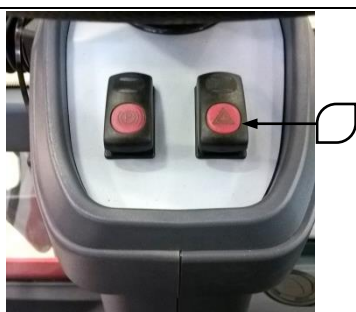

The switch for activation of the emergency lights is under the RH steering wheel.

Pressing it will switch on the emergency lights and the four direction indicators simultaneously.

To activate/deactivate the emergency lights press the relevant button.

Pedals

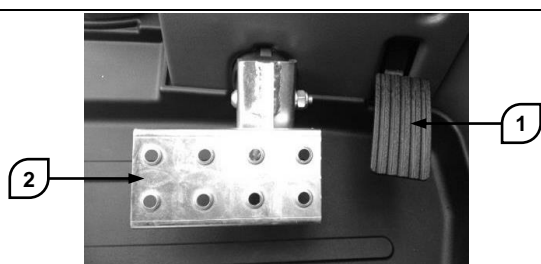

Press the accelerator pedal **[1]** to increase the I.C. engine speed.

Release the accelerator pedal to decrease the I.C. engine speed.

Press the brake pedal down all the way **[2]** to stop the vehicle.



Steering modes



Use the steering wheel to guide the movement of the vehicle. A knob is provided to drive with one hand, keeping the other free for other controls.

Do not use the knob for driving on public roads. In these situations, keep both hands on the steering wheel to have better control of the vehicle.

There are three steering modes:

-  Two-wheel steering: on front axle
-  Four-wheel steering with concurrent axis
-  Four-wheel steering with parallel axis

To change the steering modes:

- Display the main page of the multiple function display;
- Align the wheels of both axles until the green indicators light up;
- Press the button concerned for the required steering mode.

Joystick

The vehicle is provided with a joystick on the arm-rest to the RH of the driver's seat. The joysticks control the main hydraulic movements of the vehicle.



ATTENTION

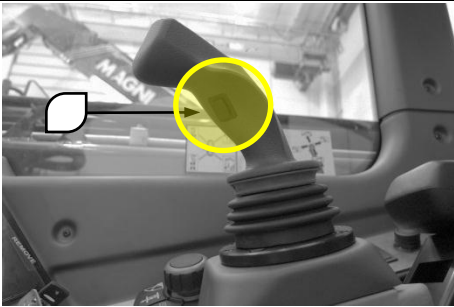

To impart commands using the joysticks, keep the confirmation button mentioned above pressed. Not pressing the confirmation button prevents accidental movements of the vehicle following involuntary activation of the joystick.

Both joysticks have their respective enable buttons.

if the enable buttons are not pressed, this is indicated by means of the banner meant for the purpose in the control panel present in the cab.



Transmission selector



The FWD/BWD movement selector is positioned in the upper part of the RH joystick and identified by a red toggle-button with three positions:

- at the centre the transmission is in NEUTRAL,

- when pushed forwards the forward movement is activated,
- when pushed backwards reverse gear is activated.

During the I.C. engine start up steps, the start selector must be in the NEUTRAL central position.



ATTENTION

The gear must be engaged (forwards or reverse) by pressing the enable button on the joystick. Otherwise the incorrect procedure will be displayed on the touchscreen panel.

Apply reverse gear only with the vehicle stopped. Otherwise the incorrect procedure will be displayed on the touchscreen panel.

Speed

The two-speed hydrostatic transmission works according to two modes:

- "tortoise", low speed ratio;
- "hare", high speed ratio.

The button for selecting these modes is present in the **main page**:



- Tortoise → hare button
- Hare → tortoise button
- Reset button

To active one or the other function, press the button and wait for the graphic display to change.

In "tortoise" mode, the transmission allows the vehicle to move at low speed. Use this mode for precision movements and to move the load.

In "hare" mode the transmission uses both speeds and makes it possible to reach maximum speed. Use this mode for travelling on roads or for rapid movements in the work area.

If necessary, it is possible to change forcibly from one mode to the other by pressing the "reset" button.

RH joystick

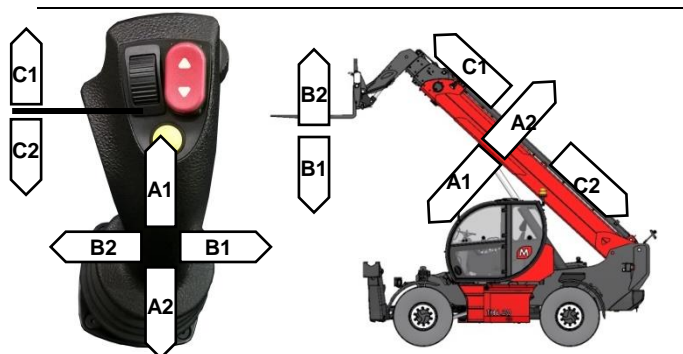

- the red toggle switch activates vehicle traction:
 - at the centre the transmission is in NEUTRAL,
 - when pushed forwards the forward movement transmission is activated,
 - when pushed backwards reverse gear is activated;
- **A1**: move the joystick forwards to lower the telescopic boom;
- **A2**: move the joystick backwards to raise the telescopic boom;
- **B1**: move the joystick to the RH to rotate the accessory downwards;
- **B2**: move the joystick to the LH to rotate the accessory upwards.
- **C1**: rotate the roller forwards to extend the telescopic boom;
- **C2**: rotate the roller backwards to retract the telescopic boom.

Side-shift control

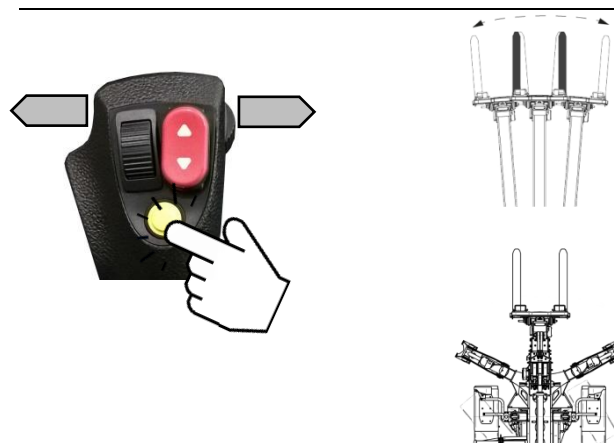

To activate the side-shift of the front axle press the yellow button on the joystick head and at the same time orient the joystick to the RH or LH to impart the same directional movement to the telescopic boom.



ATTENTION

Keep the movement enable button pressed to impact the command.

Boom head hydraulic command



The roller present in the RH outer part of the joystick activates the hydraulic connections present at the top of the boom; it controls the movements, depending on the accessories mounted: for example, in case of winch, it controls the ascent/descent of the rope; in case of overhead platform with rotary connection, it controls the direction of rotation.



ATTENTION

Keep the movement enable button pressed to impact the command.



ATTENTION

If the roller present on the joystick is activated without the help of the enable button and with the engine switched on, pressure in the hydraulic circuit sent to the accessory is discharged.

Use this procedure before disconnecting the quick-release couplings of the hydraulic circuit of the accessory at the head of the boom.

Control panel

USB socket

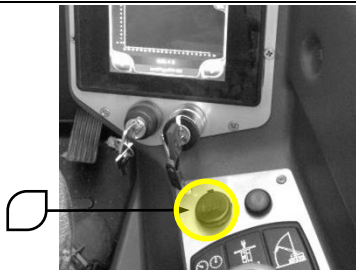

A USB socket is present under the graphic panel with the function of dialog with the software installed on the machine to make rapid update easier.

Emergency stop button



The emergency stop button is present on the PB panel to the RH of the driver's seat.

Press the emergency stop button to stop the I.C. engine and interrupt all vehicle movements.

The emergency stop button must be reset after use. If the button is not reset the vehicle cannot be restarted.

To reset the emergency stop button turn it clockwise.

Levelling on tyres

Levelling on tyres can be done by means of the switch shown below:

levelling on wheels can be done only with the following conditions:

- inclination of the telescopic boom in relation to the horizontal axis less than or equal to 30°;

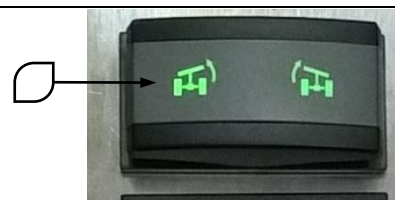

To level the vehicle manually press the switch present on the control panel to the RH of the driver's seat. Pressing the switch to the RH will cause the vehicle chassis to incline to the RH. Pressing the switch on the LH will cause the vehicle chassis to tilt to the LH.

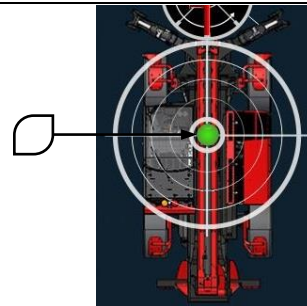

The outcome of the levelling can be checked by means of the electronic level gauge: if the vehicle is levelled correctly, the green indicator will be in the centre of the level.

Control of the stabilizers

The stabilizers can be controlled in two ways:

- with button on panel;
- with controls on the multiple function display and joypad.

Control by means of the button on the panel

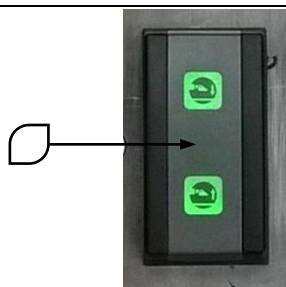

The switch controls the movements for lifting and lowering of the stabilizers.

Press on the icons present on the switches to:



lift the stabilizers



lower the stabilizers

Control by means of the multiple function display

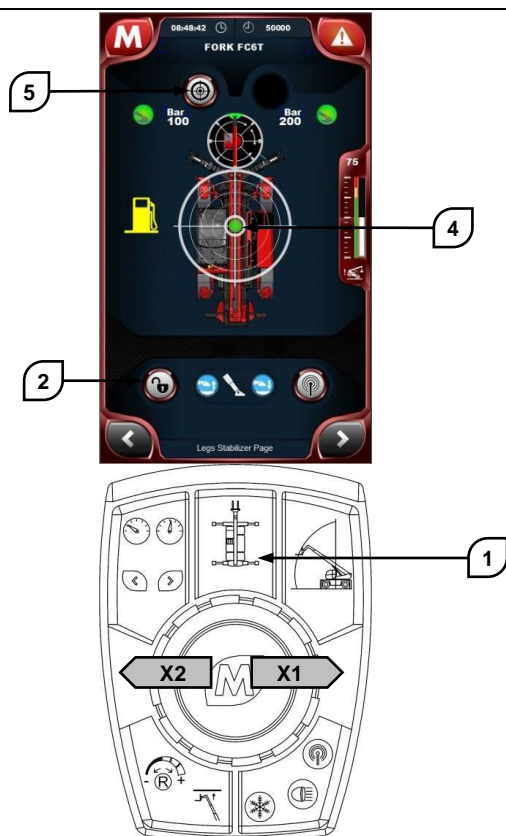

To control the stabilisers by means of the multifunction display press the button at the top centre of joypad **[1]** to display the stabilisers page.

The commands in the page are blocked by default for safety reasons. To activate these, press unlock button **[2]**.

After activating the command, use the joystick of the pad to impart the movements:

- **X1**: move the joystick to the RH to lower the stabilizers;
- **X2**: move the joystick to the LH to raise the stabilizers;

After stabilizing the vehicle, always check the levelling by means of electronic level **4**. The indicator must be in the centre of the measuring range.

The vehicle can be automatically levelled on stabilisers. For automatic levelling of the vehicle on stabilisers, press button **5**.

Exclusion of the safety systems

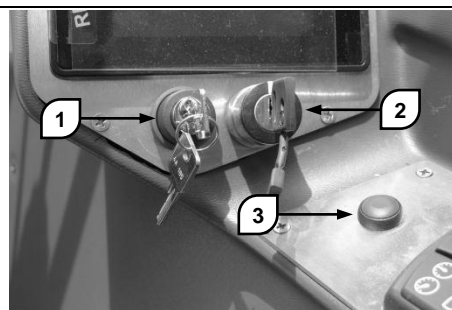

ATTENTION

Exclusion of the safety systems accompanied by inappropriate movements can cause the vehicle to tilt over, with risk of accidents and death.

Do not try to exclude the safety systems to increase the loading capacity of the vehicle.

Take the key with the metal grip from the safety keys cabinet after breaking the glass using the hammer provided.

Insert the key in **1**. Press and turn the key clockwise, holding it in position.

Perform all the necessary movements to solve the emergency and restore the vehicle to safety conditions.

Remove the key and put it back in its container. Replace the glass that was broken earlier.

Exclusion of safety systems for the lifting platform.

Take the key with the plastic grip from the safety keys cabinet after breaking the glass using the hammer provided.

Insert the key in **2**. Press and turn the key clockwise, holding it in position. Use the same hand to press and hold down button **3**.

Perform all the necessary movements to solve the emergency and restore the vehicle to safety conditions.

Remove the key and put it back in its container. Replace the glass that was broken earlier.

RADIO CONTROLS (OPTIONAL)**General information**

The vehicles can be equipped with radio control for remote control; for specific information refer to the document concerned.

BEFORE STARTING UP THE ENGINE

Visual inspection

To ensure the maximum useful operating life of the vehicle, proceed with a thorough visual inspection before every start up.

Look around and under the vehicle, checking to make sure there are no slackened or missing bolts, leakage of oil, fuel and other liquids, broken or worn parts.

Check the state of the accessories and hydraulic components.

Check the state and wear of the tyres. If necessary, adjust the inflation pressure.

Check the oil, coolant and fluid levels.

Check the AdBlue® tank level (if present).

Remove all accumulated dirt and debris. Carry out all the repairs necessary before starting up the vehicle.

Climbing on to or climbing down from the vehicle

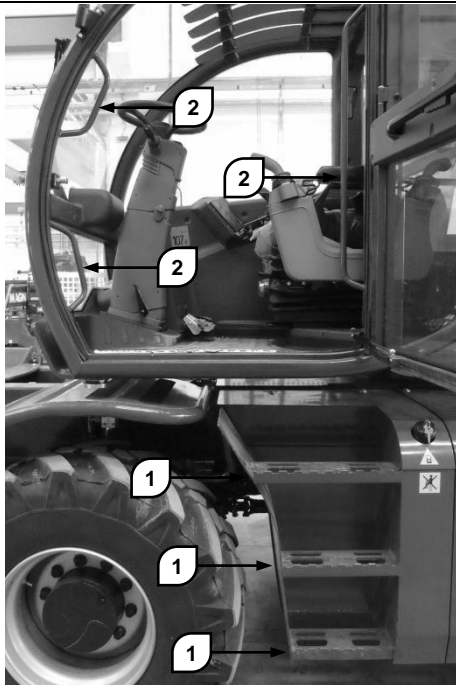

Always use steps [1] and handles [2] to climb on to or down from the vehicle.

Before climbing on to or climbing down from the cab, clean all steps and handles thoroughly. Damaged steps or handles must be repaired immediately.

Do not climb on or down from the vehicle with your back to it.

Always use three gripping points when climbing up or down: two hands gripping the handles and one foot on a step, or two feet on the steps and one hand gripping the handle.

Do not climb on or get off when the vehicle is in motion.

Do not climb or get down from the vehicle carrying tools or other objects. Load the tools required before climbing on the vehicle. Unload the tools from the vehicle using a rope to lower these to the ground.

Do not use any of the vehicle's control devices (joystick or handwheel) as a grip for climbing up or down.

Driver's seat

Adjust the seat before every work phase and every time the operator changes.

For instructions regarding the adjustment of the driver's seat, consult the relevant section of this Manual.

Always check the nuts, bolts and screws used for fixing the seat and seat belt. Replace damaged and worn parts.

STARTING UP THE ENGINE



RISK OF INTOXICATION

The exhaust from the I.C. engine always contains chemical elements that may be asphyxiating or toxic.

Start up the engine in open, well ventilated areas. If the vehicle is in a closed space, direct the exhaust gases outside by means of suitable devices.

Start up in normal conditions

- Check to make sure the reverse gear is in neutral;
- Turn the ignition key to position I to close the electric contact;
- Wait for about 10 seconds to allow the machine to run the diagnostic and preheating cycles;
- Turn the ignition key to position III and hold it in this position until the engine starts up. Do not hold the key in position III for more than 5 seconds.
- Let the engine run at minimum speed for a few minutes to bring the lubricants to the right temperature. The duration of this phase depends on the outside temperature.

Start up in extreme climates

The start up procedure in normal conditions makes it possible to start up the engine with ambient temperatures above -18° C.

To start up the engine at ambient temperatures less than -18° C use one or more supplementary devices to help the start up. These devices may be:

- A coolant heater;
- A fuel heater;
- A heater for the engine oil and hydraulic fluid;
- Batteries with greater capacity.

Before using the vehicle at temperatures less than -23° C consult your dealer instructions and technical assistance.

Start up using jumper cables



BATTERIES

The batteries generate flammable gases which can explode causing injuries to persons.

Avoid sparks near the batteries. Make sure the jumper cable ends do not come in contact with one another or with the vehicle.

Do not smoke in the vicinity of the batteries.

The electrolyte contained in the batteries is an acid and can cause burns if it comes in contact with the skin and eyes.

Always wear safety goggles and acid-resistant gloves when starting up a vehicle using jumper cables.

Incorrect connection of jumper cables can cause explosions with risk of causing injuries.

Never connect the opposite poles of the batteries to one another.

Create the jumper only using an energy source having the same voltage as the stopped vehicle.

This vehicle has a 24V system. If the batteries are unable to start up the vehicle, they may have to be replaced.

- Apply the vehicle parking brake on the vehicle to be started up. Bring the transmission to neutral. Lower the accessory to the ground.
- Turn the vehicle ignition switch to position 0;
- Bring the vehicle used as source of power supply to such a distance as to allow connection with jumper cables. **Make sure the vehicles do not touch;**
- Set the gear in neutral and apply the vehicle parking brake used as power supply source;
- Stop the vehicle engine used as source. If an emergency starter is used, cut off the power supply;
- Make sure the electrolyte level of both batteries is correct. Make sure the caps of both batteries are fitted and tightened correctly. Make sure the batteries of the vehicle to be started are not frozen;
- The positive terminals (+) of the jumper cable are red. Connect one positive terminal of the jumper cable to the positive terminal of the flat battery from which the cable connected to the starter motor branches out. Do not place the positive

- terminal in contact with any part of the vehicle other than the positive pole of the battery;
- Connect the other end of the positive jumper cable to the positive terminal of the battery of the power source;
 - The negative terminals (-) of the jumper cable are black. Connect one negative terminal of the jumper cable to the negative terminal of the electric power source;
 - Connect the other end of the negative jumper cable to the chassis of the vehicle stopped. Do not connect the jumper cable to the battery poles. Make sure the jumper cables do not touch the following elements: fuel piping, hydraulic pipes, electrical/electronic components and mobile parts.
 - Start up the engine of the vehicle used as source, or switch on the emergency starter;
 - Wait for the source to charge the vehicle batteries for at least three minutes;
 - Try to start up the engine of the faulty vehicle. For the start up procedure refer to the "start up in normal conditions" chapter;
 - Immediately after start up, disconnect the jumper cables, repeating the operations described above in reverse order.
 - Analyse the causes of the fault and carry out the necessary repairs.

After start up

Let the engine run at minimum speed. During the first 30 seconds of operation do not connect any charge to the engine.

Check all the indicators and lights. All the indicators and lights must indicate normal operating conditions.

Check on the multiple function display to see that the diagnostics button on the top RH is not flashing. If the diagnostics button flashes, immediately stop the engine, press the button to access the diagnostics page and find the causes of the fault signals.

Let the engine run at minimum speed for at least 5 minutes to heat up the oil. In case of particularly cold climates more than 5 minutes of heating may be necessary. Use this period of time to heat the hydraulic fluid, operating the joysticks to raise and lower the telescopic boom.

Releasing the parking brake

To release the vehicle's parking brake, follow the criteria given below:

- sit correctly in the seat inside the cab,
- with the engine running, check to make sure the gear lever is in the NEUTRAL position,
- press button (P) positioned on the steering column under the handwheel for 3 seconds and check to ensure the indicator lights on the panel switches off.

After following the procedure, select the gear and move the vehicle in the required direction.

OPERATING TECHNIQUES



ELECTRICITY

If the vehicle is very near electricity lines, current may flow through it causing injuries or even death.

Keep the vehicle at a distance of at least 10m from the electricity lines. Always check for the presence of overhead electricity lines before operating the boom.



ATTENTION

The lack of stability of the vehicle can cause serious or mortal injuries. To ensure the stability of the vehicle the following conditions must be satisfied.

Inflate the tyres to the correct pressure.

Always level the vehicle, whether on tyres or on stabilisers.

Do not try to by-pass the safety systems unless strictly necessary for the safety of the vehicle and the operators.

Do not tamper with the accessory identification systems.

Do not operate the vehicle with the boom in a position other than that for transport.

Fitting the fork carriage



ATTENTION

If fitted incorrectly, an accessory can get detached accidentally during the working of the machine. This can cause accident or even death.

Do not operate the machine without the shear pin fitted in the quick-fit coupling.

Position the accessory on a stable level surface. Make sure there is sufficient space for operation. Check the accessory to make sure it is clean and intact before fitting it.

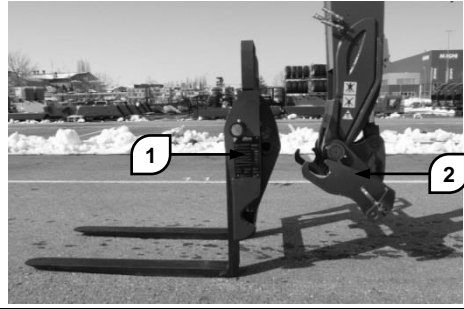

Bring the vehicle perpendicular to the accessory with the boom completely retracted and lowered. Retract the slewing cylinder to make hook up easier.

Stop the vehicle with the quick-fit device about a meter away from the accessory. Move the reverse gear lever to the neutral position and apply the parking brake.

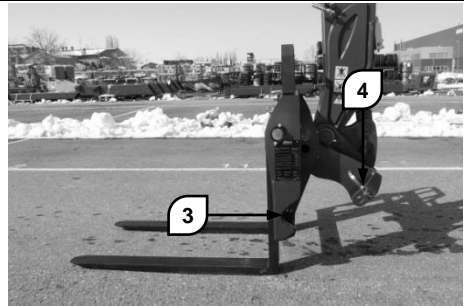

Extend the telescopic boom slowly, checking the alignment, then raise it to fit the accessory. Raise the accessory by a few centimetres off the ground to ensure the elements fit in perfectly.



Rotate the quick-fit coupling until it is aligned perfectly with the accessory.

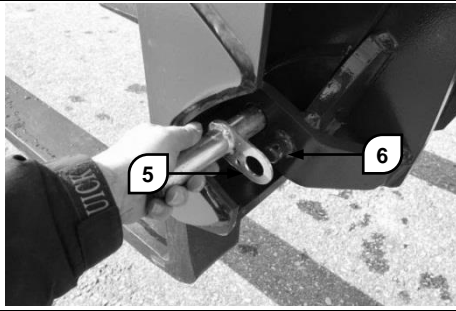

Figure 1

Take the shear pin from its housing and insert it in all the way, taking care to align hole 5 correctly with locator 6.

Complete the procedure by inserting the split pin in the hole of locator 6 to prevent the shear pin from coming loose accidentally.



Hydraulic shear pin

If the vehicle supply includes a hydraulic shear pin, an option valid for type “I” as well as type “U” coupling, keep the spring button with the relevant screen print present in the RH of the cab above the cigarette lighter pressed,



and simultaneously turn the roller on the joystick LH forwards until the locking pin comes completely out of the quick-fit coupling.

The multiple function display shows the name of the accessory identified by the automatic identification system. Two buttons are displayed under the accessory name:



Accessory confirmation



No accessory confirmation

Press the confirmation button if the accessory identified corresponds to that actually fitted on the vehicle.

Press the no confirmation button if the accessory identified does not correspond to that fitted on the vehicle. The vehicle can however be used, but the functionality and load capacity are limited for safety reasons.

If no accessory is fitted on the forklift truck, confirm the absence of the element by pressing the green validation button.

Dismantling the fork carriage

Position the vehicle on a stable level surface. Make sure there is sufficient space for operation. Move the reverse gear lever to the neutral position and apply the parking brake.

Remove the split pin and then the shear pin. Refit the shear pin in its place on the vehicle chassis.

Lower the telescopic boom and rest the accessory gently on the ground. Rotate the quick-fit coupling downwards to make it easy to detach the accessory.

Lower the telescopic boom to separate the forklift truck from the accessory. Retract the boom completely to separate the quick-release coupling from the accessory.

Clean the accessory thoroughly. Grease all the pins and mobile parts to protect these from corrosion and wear. Remove excess grease to prevent accumulation of dirt.

Always keep the accessory protected from atmospheric agents. Rest the accessory on a support raised off the ground and protect it with a waterproof cover if necessary.

Handling of loads

During load handling operations always display the load control page to keep the percentage indicator and load chart under control.

If the load status indicator is in alarm, make only the unloading movements in the following order:

- Retract the telescopic boom as far as possible;
- Lift the telescopic boom if necessary;
- Lower the boom to deposit the load.

Never try to extend the telescopic boom when the load indicator shows an alarm signal.

Before picking up the load always check to make sure the vehicle is levelled using an electronic level gauge.

Centre of gravity of the load

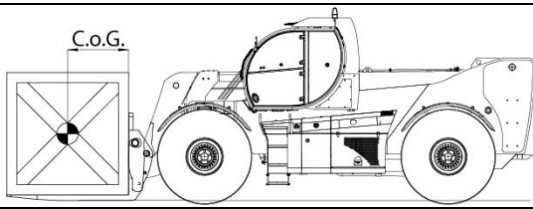

Do not try to lift loads under any circumstances whatsoever

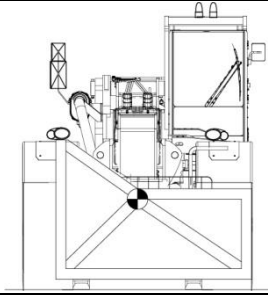

in case of irregular loads, determine the centre of gravity in the transverse direction to the vehicle before making any movement.

For loads with mobile centre of gravity, such as tanks containing liquids, it is necessary to take into account the load oscillations and take utmost caution in handling to avoid excessive shifting of the centre of gravity.

Picking up a load from the ground



DANGER OF CRUSHING

During manual adjustment of the forks there is danger of crushing of the limbs. This can lead to serious injuries.

Take utmost care while making manual adjustments.

Position the vehicle at right angles to the chosen load.

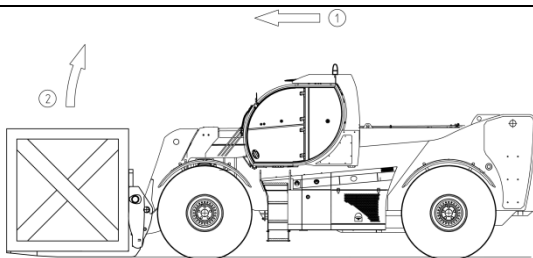

Manually adjust the width of the forks so that these can be inserted in the openings in the pallet at the base of the load. If there is no pallet, adjust the forks

to the maximum width to give the load maximum stability.

Incline the quick-fit coupling so that the forks are not in the horizontal position. Approach the load slowly with the boom lowered and insert the forks under it.

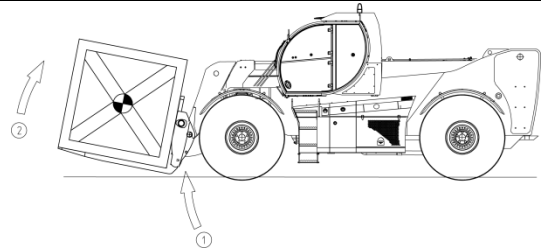

Apply the parking brake and set the reverse gear lever in the neutral position.

Lift the load slightly and incline the quick-fit coupling upwards to make the load stable. Take care to avoid modifying the load balance negatively (overturning in the direction of movement).

Picking up a load at a height

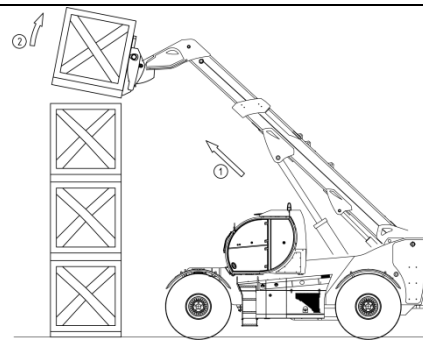

Position the machine perpendicular to the load concerned. Make sure the forks pass under the load and are adjusted suitably depending on the load.

Bring the vehicle near the load slowly with the forks in the horizontal position. Move carefully to insert the forks under the load. The forks must enter the pockets of the pallet all the way with precision. Take care to avoid knocking against the load.

Apply the parking brake and set the reverse gear lever in the neutral position.

Lift the load slightly. Incline the quick-fit coupling upwards to make the load stable, taking care to avoid modifying the balance negatively.

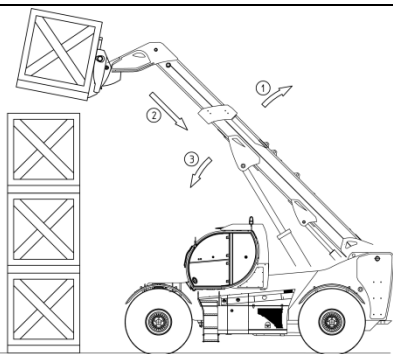

If possible, lower the load without moving the forklift truck. Lift the boom to move the load away. Retract the telescopic boom and lower it to bring the load to the transport position.

If the load cannot be lowered without shifting the vehicle, move gently in reverse and with utmost care to move the load away. Retract the telescopic boom and lower it to bring the load to the transport position.

Bring the load to the transport position

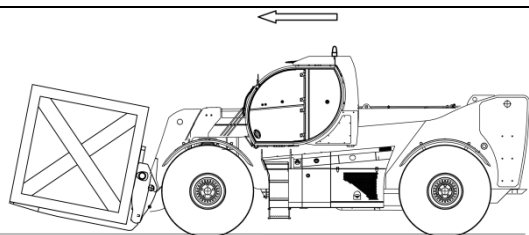

Every time reference is made to the “transport position” in this Manual, it means the configuration of the machine is as described below:

- Stabilisers completely retracted and raised;
- Telescopic boom completely retracted;
- Quick-fit coupling rotated slightly upwards;
- Telescopic boom lowered in such a way as to keep the load approx. 300 mm off the ground.

Driving the vehicle

Move the vehicle with the accessory in transport position, i.e. with the boom completely retracted and the load approx. 300 mm above the ground.

The speed of the forklift truck with load must never exceed 10 km/h.

Drive carefully, adjusting the speed according to the stability of the vehicle and the ground conditions. Slow down on bends. Avoid sudden action on the vehicle controls. Never operate the vehicle with the load in a position other than that for transport. Avoid

grounds where there is risk of inclining or overturning the vehicle. Use the rear-view mirrors frequently.

Never leave the vehicle unattended with the engine running.

Do not bring the vehicle to rest on any structure unless you are sure it can stand the weight and dimensions of the vehicle without risk for safety.

PARKING THE VEHICLE

Parking position

The parking position is a machine configuration suitable for parking and carrying out routine maintenance. Always leave the vehicle in the parked position when it is not working, unless expressly indicated in this Use and Maintenance Manual.

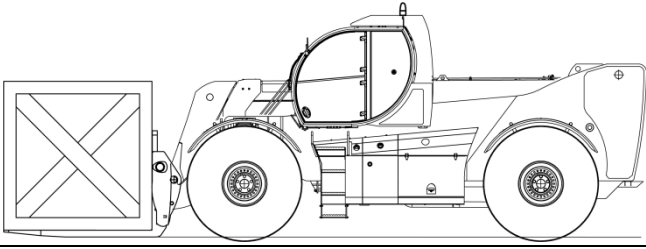

A parked vehicle has the following configuration:

- Gear in idle;
- Parking brake applied;
- All wheels aligned;
- Stabilisers completely raised;
- Telescopic boom completely retracted, or with accessory resting on the ground;
- Engine switched off and ignition key deactivated.

Stopping the vehicle

Park the vehicle on level ground as far as possible. If the vehicle is to be parked on a slope, block all four wheels with wedges.

Do not park the vehicle with a load hanging from the accessory.

Use the service brake pedal to stop the vehicle. After stopping move the gear lever to neutral and apply the parking brake. Release the service brake pedal and make sure the vehicle cannot move.

If the vehicle is to remain parked for a long period, protect it from atmospheric agents.

Before stopping the engine let it run at minimum for a few minutes. Immediately stopping the engine after it has been working under load can cause overheating and premature wear of some of the components.

Leaving the vehicle

Remove the ignition key.

Before leaving the cab, shut all windows and make sure they are locked properly.

Get down from the vehicle and lock the cab door shut.

Open the engine compartment and check for debris. Remove any debris or paper if present to prevent risk of fire.

Turn the battery disconnect switch to switch off the main circuit. This will prevent a short circuit and damage to the batteries and will preserve the charge from abnormal power draws.



ATTENTION

For drive units satisfying the Stage IV anti-pollution standards, wait at least 5 minutes after the I.C. engine is switched off, before acting on the main electric circuit to disconnect it. This will help protect the AdBlue purification plant.

Lock the engine compartment with a key. Lock the compartment at the back of the cab and on the LH side of the vehicle with a key. Lock the fuel tank cap with a key.

Before leaving the vehicle, check all the locks. Install a waterproof covering to protect the vehicle from atmospheric agents if it is to remain unused for a long period.

INFORMATION REGARDING TRANSPORT

Shipping the vehicle

Make sure the total weight of the machine and transport vehicle comply with the standards and regulations in force in the countries along the route.

Ensure that the road chosen has vertical and horizontal margins suitable for the transport vehicle with the machine loaded on it.

Before loading the machine, remove all slippery material from the transport vehicle, railway carriage or loading ramp.

Before loading the machine, always block the wheels of the transport vehicle or railway carriage with wedges.

The boom must be completely retracted and lowered, until the quick-fit coupling or accessory come to rest on the transport vehicle.

The dimensions and weights for shipping a standard machine are shown in this Use and Maintenance Manual in the technical specifications.

Travelling by road with the machine

The machine must conform to the road travel codes of the country in which it is to be used. Consult your dealer for additional information on the matter.

Observe the general rules on the matter of road travel in force in the country in which the machine is to be used.

While travelling on roads, only use the mode with two steering wheels.

Travel with the telescopic boom completely retracted and lowered as far as possible. Make sure the quick-fit coupling or the accessory is at a suitable distance from the ground.

It is forbidden to transport loads by road. It is also forbidden to travel by road with the accessory fitted on the quick-fit coupling.



The only accessory allowed for travelling on roads is the forks carriage, provided it is in position for road travel.

Positioning the forks for travelling on roads



DANGER OF CRUSHING

The fork carriage contains mobile parts which can cause crushing of the limbs.

The weight of a single fork can cause loss of control, leading to accidents, that may sometimes be serious. Always take the help of one or more operators for handling the forks manually.

Fit the fork carriage.



Make sure the quick-fit coupling is rotated slightly upwards to make the forks stable for the successive steps.

All the operations described below must be repeated for both forks.

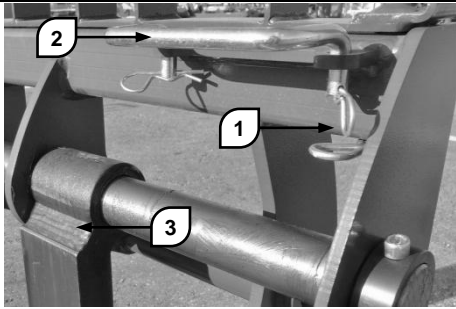

Remove the two split pins **1** from shear pin **2**. Remove shear pin **2** from its seat. Align fork **3** manually with the shear pin seat.



Hold fork **3** firmly as far away as possible from the rotation pin. Rotate the fork upwards until it comes to rest near the shear pin seat.

Refit shear pin **2** in such a way as to block the rotation of the fork. Insert the two split pins **1** to block the shear pin.

Lifting and anchoring the machine



ATTENTION

If the machine slips during transport, it can cause injury or even death.

The machine may slip if inadequate procedures or equipment are used for transport. Use suitable procedures and equipment for transport.

Lifting

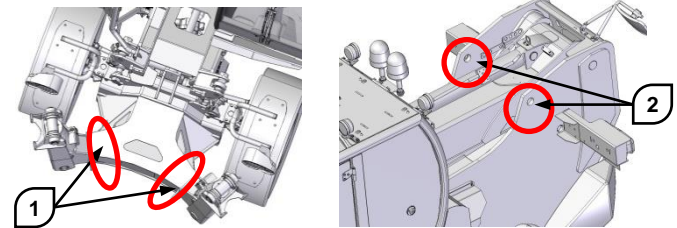
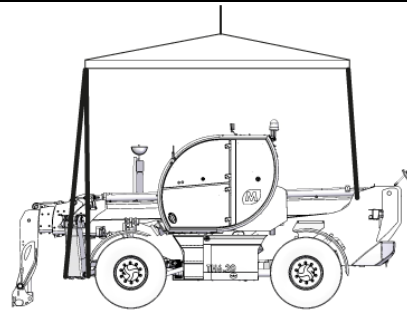

Use equipment approved for the weight of the machine to be lifted together with the accessory.

The configuration of the lifting devices must be such as to avoid damage to the machine.

Wind the lifting belts in positions **[1]** and insert the lifting hooks in points **[2]** as shown above.

Anchoring

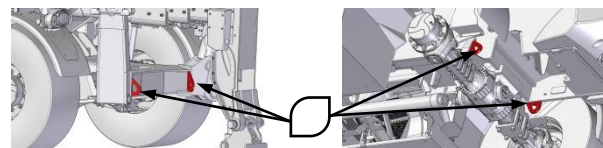
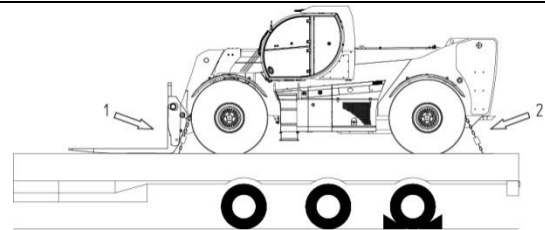

Install anchoring devices approved for the weight of the machine with accessory. Fix the anchoring devices at the four points indicated.

Block the front and rear wheels of the machine with wedges. Insert the wedges from both sides of each tyre.

Apply the parking brake and set the gear lever in neutral.

Make sure the boom is completely retracted. Make sure the boom is lowered and the accessory rests on the surface of the transport vehicle.

Stop the engine and remove the ignition key. Get out of the vehicle and close all windows, doors and compartments.

If in doubt, contact your dealer for information and assistance.

Towing the vehicle



ATTENTION

Towing the vehicle using an incorrect procedure can cause serious accidents.

Before disengaging the negative brake manually, block the machine to prevent its movement.

Follow the instructions given below to tow the machine correctly.

Towing a faulty machine must be done only for short distances and at speeds not exceeding 10 km/h. If the machine is to be transported for longer distances and at higher speeds, use a suitable transport vehicle.

Before towing the vehicle, retract and lower the telescopic boom completely and remove the load.

Do not use chains for towing the machine. Use steel cables with rings at the ends, or a special rigid tow bar. Make sure the cable is in good condition. Make sure the cable has a nominal carrying capacity 1.5 times the weight of the vehicle to be towed.

Position the reversing gear lever in the neutral position. Apply the parking brake. Switch on the emergency lights. Block the wheels of the machine with wedges.

Connect one end of the cable to the two front eyelets on the towing vehicle. Connect the other end of the cable to the two front eyelets of the vehicle to be towed.

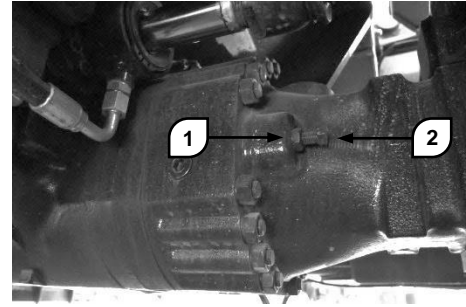

Go under the vehicle near the front axle. Unscrew lock nut **1** of power screw **2**. Tighten the power screw completely. Tighten further through another turn to deactivate the negative command brake. Repeat the operation for both screws on the same axle.

Have an operator climb on the machine to be towed to control the braking and steering. An observer must stand in a safe position to check the outcome of the operations. The observer must not stand on the vehicle to be towed.

Disengage the parking brake and remove the wedges. Tighten the tow cable slowly. Avoid sudden movements to avoid overload on the cable. Keep the angle between the machine and the towing cable minimum; it must not exceed 30° in any case whatsoever.

Because of the impossibility of listing all the precautions and towing procedures for all the situations, it is advisable to consult your Dealer for assistance.

Manual positioning of the gear in neutral.

The gear must be positioned manually in case of malfunctioning of its lever because of a hydraulic failure.

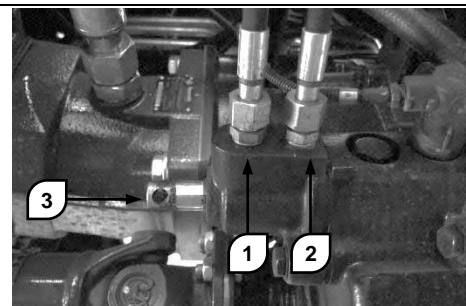

Move under the vehicle near the front axle from the RH side. Identify the hydrostatic transmission and hydraulic actuator of the gear.

Disconnect unions **1** and **2** from the actuator, and plug the ends of the tubes with suitable sized screw caps.

Using a tool as lever, shift rod 3 of the actuator to the intermediate position. There is a “click” when the actuator moves from one position to another.

Complete the operation by detaching the universal shaft from the transmission shaft by unscrewing the screws.

MAINTENANCE

General information

Tightening torques



ATTENTION

Unsuitable bolts or those of incorrect size can cause damage, faults and injuries.

Take care to avoid mixing metric nuts and bolts with nuts and bolts in inches.

The tightening torques shown below are meant as general reference. Exceptions are indicated on a case by case basis.

Before fitting any component, make sure it is as good as new. Bolts and threads must not be worn or damaged. The threads must not have burrs or be chipped.

The components must not be rusty or corroded. Clean the components with a non-corrosive detergent. Do not grease the threads of the bolts unless otherwise specified.

Metric nuts and bolts

Diameter	Tightening torque
M6	12 ± 3 Nm
M8	28 ± 7 Nm
M10	55 ± 10 Nm
M12	100 ± 20 Nm
M14	160 ± 30 Nm
M16	240 ± 40 Nm
M20	460 ± 60 Nm
M24	800 ± 100 Nm
M30	1600 ± 200 Nm
M36	2700 ± 300 Nm

Nuts and bolts in inches

Diameter	Tightening torque
1/4	12 ± 3 Nm
5/16	25 ± 6 Nm

3/8	47 ± 9 Nm
7/16	70 ± 15 Nm
1/2	105 ± 20 Nm
9/16	160 ± 30 Nm
5/8	215 ± 40 Nm
3/4	370 ± 50 Nm
7/8	620 ± 80 Nm
1	900 ± 100 Nm
1 1/8	1300 ± 150 Nm
1 1/4	1800 ± 200 Nm
1 3/8	2400 ± 300 Nm
1 1/2	3100 ± 350 Nm

Tube clamps

For fitting on a new tube:

Width	Tightening torque
7.9 mm	0.9 ± 0.2 Nm
13.5 mm	4.5 ± 0.5 Nm
15.9 mm	7.5 ± 0.5 Nm

For a second assembly:

Width	Tightening torque
7.9 mm	0.7 ± 0.2 Nm
13.5 mm	3.0 ± 0.5 Nm
15.9 mm	4.5 ± 0.5 Nm

Inflating the tyres



ATTENTION

Use a quick-release coupling and keep behind the tread when inflating the tyres.

Appropriate equipment and training are necessary to avoid excessive inflation. Inadequate procedures can cause a tyre to burst or breakage of a rim.

Before inflating a tyre, install it on the vehicle or on a device to hold it steady.

Inflation with air

Adjust the tyre inflation apparatus regulator to not more than 0.5 bar more than the inflation pressure.

In case of doubt regarding the inflation pressure for fitted tyres, contact your dealer.

Standard inflation pressures

The inflation pressures given below are those for cold inflation and standard shipment of Magni machines.

The inflation pressures may vary depending on the conditions of use. For more information, contact the tyres supplier.

Do not fill tyres with foam. Tyres filled with foam can damage certain components of the machine. Using tyres filled with foam can invalidate the warranty.

It is permitted to use liquid sealant in tyres. Make sure the maximum weight of the vehicle is not exceeded after filling with liquid sealant. If the maximum weight of the vehicle is exceeded the warranty and the certification of certain components and structures may be cancelled.

Vehicle	Tyre	Pressure
All	445/65 R22,5	8.3 bar

Tyres inflated in the workshop (approx. 18° C to 21° C) will be deflated if the machine works at temperatures below zero. Adjust the tyre pressure in case of environmental temperatures less than 0° C.

For machine supplies with optional tyres, check the correct inflation value shown on the sticker applied near each wheel under the mudguard or contact the Magni TH After-Sales Dept.

Washing



ATTENTION

While cleaning the vehicles, avoid using high pressure water jets on visible and invisible connectors: under the cab, at the head of the telescopic boom, inside the rear cab compartment, on the transducers of the valves, on all the micro switches.

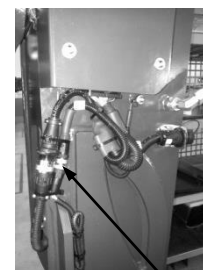

ATTENTION

While cleaning the vehicle, avoid aiming high pressure water jets directly at the hydraulic hoses of the telescopic boom.



Liquids and lubricants

Compartment	Type	Strength	°C (min/max)	Litres
<i>Cooling circuit</i>	KEMETYL Carix Premium Longlife	50%/50%*	-41	23
		35%/65%*	-22	
<i>Fuel tank</i>				150
<i>AdBlue tank</i>	ISO 22241-1 (AdBlue)			10
<i>Engine sump</i>	DQC III LA DCQ IV LA	SAE 5W30	-27/+30	9
		SAE 5W40	-30/+40	
		SAE 10W30	-20/+30	
		SAE 10W40	-20/+40	
		SAE 15W30	-15/+35	
		SAE 15W40	-15/+40	
<i>Front axle gear</i>	Oil	SAE 85W90	-27/+77	2,8
<i>Front/rear axles differentials</i>	Oil	SAE 85W90	-27/+77	11
<i>Wheel reduction gears</i>	Oil	ISO 150	-27/+77	1,6
<i>Hydraulic fluid tank</i>	Oil (SHELL Tellus S3 V)	ISO 46	-15/+130	170
<i>Greasing points</i>	Grease	NGLI 2	-30/+120	q.s.
<i>Boom sliding</i>	Grease (KERNITE Delavan)	PTFE NLGI 2	-20/+150	q.s.

* The percentages correspond, in the order, to the composition of the antifreeze+distilled water mixture:

- 50%/50% means a mixture in equal parts;

- 35%/65% corresponds to a mixture of 35% anti-freeze and 65% distilled water.

Spares for routine maintenance

Position	Description	Quantity	Code
<i>Alternator transmission belt</i>	Belt	1	24207
<i>Compressor transmission belt</i>	Belt	1	24230
<i>Air conditioning filter</i>	Filter cartridge	1	09371
<i>Cab air filter</i>	Filter cartridge	1	15291
<i>Engine air filter</i>	Primary air filter cartridge	1	31461
<i>Engine air filter</i>	Safety filter cartridge	1	31459
<i>Fuel filter</i>	Filter cartridge	1	24309
<i>Fuel pre-filter</i>	Filter cartridge	1	24293
<i>Hydraulic transmission fluid filter (delivery/suction)</i>	Filter cartridge	1	23094
<i>Engine oil filter</i>	Filter cartridge	1	24289
<i>Hydraulic oil tank vent</i>		1	31480

MAINTENANCE SCHEDULE

Read and understand all the warnings and instructions before starting any maintenance operation.

Before carrying out any maintenance operation, make sure all the scheduled actions have been carried out as planned.

As required

Telescopic boom chain - adjustment

Transmission belt - replacement

AdBlue filter

Fuel tank - refuelling

Window washing liquid tank - filling

Every 10 hours of operation or daily

Engine oil - check

Coolant - check

Telescopic boom sliding blocks – check

Liquid leaks – check

Fork carriage – daily inspection

Emergency hydraulic pump – operating test

Wheels - check the tyre pressure

Every 50 hours of operation or every 2 weeks

Transmission shaft – lubrication of universal joints

Axles – lubrication of oscillation bushes

Axles – lubrication of levelling cylinders pins

Hydraulic fluid - check

Telescopic boom sliding blocks – lubrication

Telescopic boom pins – lubrication

Forks carriage – cleaning and lubrication

Fuel prefilter – discharge water

Wheels – check tightening of nuts

Stabilisers – lubrication of pins

Every 250 hours of operation or every 3 months

Telescopic boom chains – checking and lubrication

Transmission belt - check

Differentials oil - check

Two-speed reduction gear oil – check

Wheel reduction gears oil – check

Steering elements – lubrication

Every 500 hours of operation or every 6 months

Hydraulic oil filter – replacement (suction)

Hydraulic oil filter – replacement (drainage)

Engine oil and filter – change

Fuel prefilter – replacement

Engine radiator – cleaning

Engine pipes – inspection

Every 1000 hours of operation or every year

Telescopic boom chains – check for wear

Fuel filter – replacement

AdBlue filter – replacement

Air filter – primary cartridge replacement

Valves play – checking and adjustment

Differentials oil - change

Two-speed reduction gear oil – change

Wheel reduction gears oil – change

Telescopic boom sliding blocks – adjust play

Forks carriage – yearly inspection

Fuel tank - clean

Every 1500 hours of operation

Fuel filter – clean mesh element

Fuel prefilter – replacement

Every 2000 hours of operation or every 2 years

Hydraulic fluid - change

Air filter – safety cartridge replacement

Coolant - change

MAINTENANCE OPERATIONS

Transmission shaft

Lubrication of universal joints

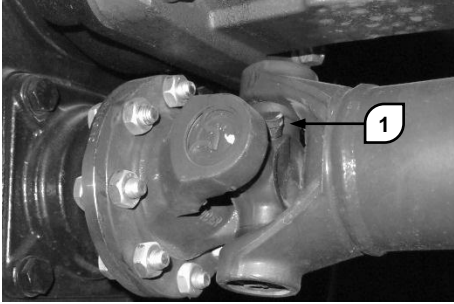

Set the vehicle in the parking position. Make sure no one approaches the work area.

Lubricate the universal joints by injecting grease into the grease nipples **1**. Repeat for all the transmission shaft joints. Remove the excess grease.

Axles

Lubrication of oscillation bushes

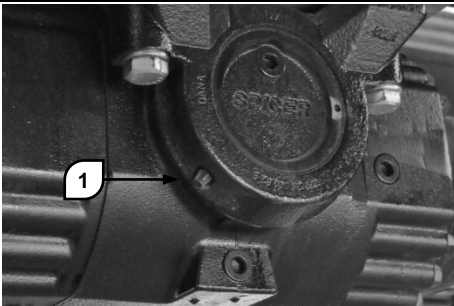

Set the vehicle in the parking position. Make sure no one approaches the work area.

Stand near the front axle oscillation bushes. Inject grease in the grease nipples **1** present on both sides of the axle (front and rear).

Repeat the lubrication for the rear axle.

Lubrication of levelling cylinders pins

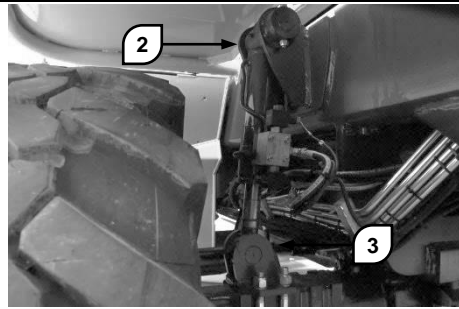

Set the vehicle in the parking position. Make sure no one approaches the work area.

Access the levelling cylinders present behind the wheels of the vehicle. Lubricate pins **2** and **3** by injecting grease in the grease nipples provided for the purpose.

Telescopic boom chains

Checking and lubrication



Position the vehicle on stabilizers. Centre the front axle of the forklift truck (sliding) and extend the telescopic boom completely in the horizontal position.

Clean the chains and inspect carefully for signs of wear. Brush thoroughly to remove impurities. For maximum efficiency use a hard nylon brush and clean fuel.

Blow on the chains with compressed air. Lubricate with a brush soaked in oil. Wipe excess oil using a clean cloth.

Lubricate the pins of the rotation pulleys by injecting grease in the grease nipples provided for the purpose.

Repeat the operations for all the outer chains and for all the pulleys of each extension of the telescopic boom.

Adjustment

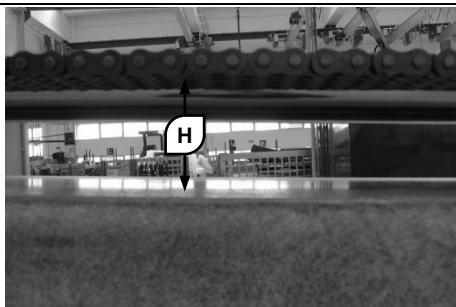

The services of an operator and an inspector are required to check the chains to see if they require adjustment.

Extend the telescopic boom in the horizontal position. Provide a rapid pulse to retract the boom and observe the oscillation of the chains. If, during oscillation, distance **H** is less than 4 cm, the chain must be adjusted.

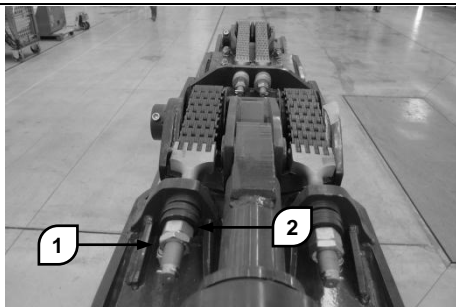

To adjust the chain, first slacken lock nut **1**, then turn screw **2** clockwise to increase the chain tension, or counter-clockwise to decrease it.

Measure the distance between the chain axis and the surface of the boom. The reference values are:

- first extension: min. 85 mm, max. 100 mm;
- second extension: min. 65 mm, max. 80 mm.
- third extension: min. 70 mm, max. 80 mm.



ATTENTION

Take special care to avoid tightening the chains excessively. Breakage of a chain following incorrect adjustment without the dealer's assistance can lead to serious damage.

Checking for wear

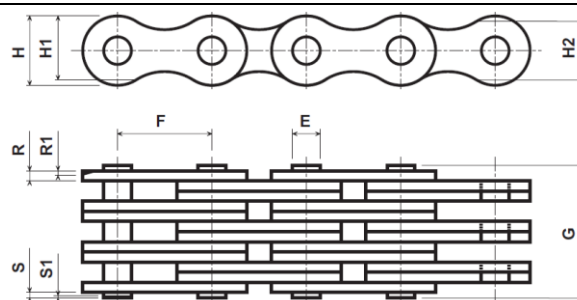

To check the chains for wear, the main structural dimensions of the chains of each extension must be known. Take measurements of a new chain or contact your dealer for this information.

Position the vehicle on stabilizers. Centre the front axle of the forklift truck (sliding) and extend the telescopic boom completely in the horizontal position.

Measure the lengthening of the chain due to wear. Take the measurements on sections with 15-18 links. Use the heads of the pins as reference. If the lengthening of any of the sections is found to be $\geq 2\%$, the chain must be replaced.

Check the wear on the plates profile (H1 or H2) and compare with a new chain (H). If the chain is found to be $[(H-H1)/H] \times 100 \geq 2\%$ or $[(H-H2)/H] \times 100 \geq 3.5\%$ at any point, it must be replaced.

Check the wear on the edge of the plates and on the heads of the pins. If in any point the chain is found to be $(R1/R) \times 100 \geq 25\%$ or $(S1/S) \times 100 \geq 20\%$, it must be replaced. Since this is a case of abnormal wear, before making the replacement, check for the causes of wear and implement corrective measures.

Repeat the measurements for all the chains. For each chain, take a number of measurements on a number of sections to check non uniform wear. Always take the most worn area as reference.

For replacement of one or more chains, contact your dealer for assistance.

Retiming the boom



ATTENTION

Before operating, check the phase displacement of the telescopic boom extensions: if a certain phase displacement is ascertained, solve the problem by acting immediately on the extensions closure command until the boom is retracted completely.

A misalignment greater than 50 mm involves risk of breakage of the hydraulic pipes inside the boom.

Transmission belt



ATTENTION

Work on the transmission belt only with the engine stopped! After repairs, make sure all the protection devices have been refitted and that no tool has been forgotten on the engine.

Checking the belt tension

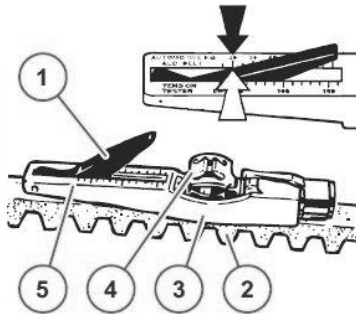

To check the tension of the belts, lower the arm of indicator (1) in the tester.

Place the guide (3) between two pulleys on the V-belt (2). At this point, the stop must be on the side.

Press button (4) in the RH corner with respect to V-belt (2) uniformly until the spring clicks audibly.

Lift the tester gently, without modifying the position of the indicator arm (1).

Read the value measured on the intersection point (arrow), scale (5) and indicator arm (1).

Correct the tension if necessary and repeat the measurement.

The belt tension tester can be ordered through the Customer Service.

Replacement

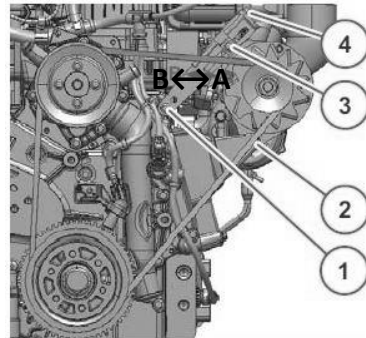

(1) screw, (2) screw, (3) screw, (4) adjuster wrench.

To replace the transmission belt:

- slacken the screw and lock nut,
- move the generator above the adjuster wrench in direction (B) until the belt slackens,
- remove the belts and fit the new ones,
- reposition the generator above the adjuster wrench in direction (A) until the belt tension is correct,
- check the belt tension:
 - pretensioning 650 ± 50 Nm
 - correct tension 400 ± 50 Nm
- tighten the screw and lock nut.

Tightening torque:	screw (1)	30 Nm
	screw (2)	42 Nm
	screw (3)	30 Nm

Engine oil



ATTENTION

Do not operate with the engine running!

It is forbidden to smoke and use naked flames!

Danger of burns!

During operations on the lubricant oil system, ensure utmost cleanliness. Thoroughly clean the area around the components involved from time to time.

Dry the damp parts with air jets. For handling lubricant oils follow the safety directives and specific local standards.

Dispose of the leaked lubricant oil and the filter elements. Do not let the used lubricant oil spread in

the ground. Run a test cycle after every intervention. At the same time, ensure sealing and pressure of the lubricant oil and then check its level.

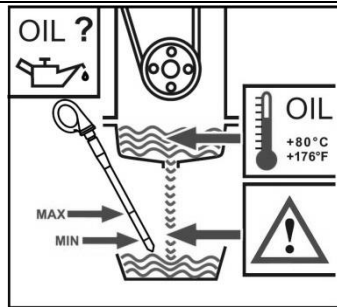

An insufficient and/or excessive lubricant oil level can damage the engine. Check the oil level only with the engine horizontal and stopped. Check the lubricant oil level only while it is warm, 5 minutes after the engine is switched off. Do not remove the oil level rod with the engine running. Danger of burns.

Checking the engine oil level

Remove the rod and wipe it clean with a cloth, do not leave fibres.

Insert the oil rod up to the stop then remove it and read the lubricant oil level.

The level must be between the MIN and MAX level! Top up to the MAX notch if necessary.

Engine oil temperature

Heat the engine until the oil temperature reaches > 80° C.

Park the vehicle on a horizontal surface and stop the engine.

Place a container under the drain screw, unscrew the latter and drain out the lubricant oil.

After draining, reposition the screw with a new sealing ring and tighten by applying a 55 Nm torque.

Fill lubricant oil, warm the engine to a temperature > 80° C and check the lubricant oil level.

Top up, if necessary.

Replacing the lubrication oil cartridge



Slacken the filter using the tool and unscrew it.

Collect the lubricant oil that flows out.

Wipe the surface of the filter-holder with a clean cloth that does not leave lint.

Oil the original DEUTZ filter cartridge seal slightly.

Manually screw the new filter tightening it by applying a 10-12 Nm torque.

Fuel prefilter



FLAMMABLE MATERIAL

Fuel is flammable and can cause severe burns and death.

Do not smoke or use naked flames while working on the fuel line.

Clean the engine parts and engine compartment to remove all trace of fuel to prevent risk of fire.

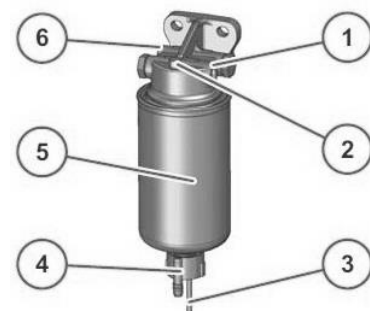

(1) pump fuel supply, (2) bleed screw, (3) electric connection for the water level sensor, (4) drainage cap, (5) filter cartridge, (6) fuel tank inlet

Emptying the water container

Stop the engine.

Place a suitable container.

Electrical connection

Disconnect the cables.

Slacken the drainage screw.

Drain the liquid until the pure diesel fuel starts flowing out.

Fit the drainage cap by applying a tightening torque of 1.6 ± 0.3 Nm.

Connect the cables.

Replacing the fuel filter cartridge

Stop the engine.

Block the fuel intake to the engine (if the tank is positioned at the top).

Place a suitable container.

Electrical connection

Disconnect the cables.

Slacken the drainage cap and drain out the liquid.

Remove the filter element.

Wipe the surface of the new filter cartridge and the opposite side of the filter head to remove dirt.

Slightly dampen the surfaces of the filter cartridge with fuel and re-screw the filter head clockwise (17-18 Nm).

Fit the drainage cap by applying a tightening torque of 1.6 ± 0.3 Nm.

Connect the cables.

Open the fuel cock and bleed the system (see "Bleeding the fuel system").

Tighten the clamps of the anti-twisting safety (optionals).

Bleed the fuel supply system.

Bleed the fuel supply system.

The fuel supply system is bled by means of the fuel delivery electric pump.

To make sure fault messages are not generated, try not to start up during the bleeding process.

This process is carried out as described below:

Switched on.

The fuel delivery electronic pump is activated for 20 seconds to bleed the fuel supply system and generate the necessary fuel pressure.

Wait for the fuel delivery electric pump to be deactivated from the control unit.

Switch off.

Repeat the process at least twice until the fuel supply system bleeding is complete.

Fuel filter



Replacement

Slacken the filter using the tool and unscrew it.

Collect the fuel that flows out.

Wipe the surface of the filter-holder with a clean cloth that does not leave lint.

Oil the original DEUTZ filter cartridge seal slightly.

Manually screw the new filter tightening it by applying a torque of:

Nm

AdBlue filter



RISK OF INTOXICATION

The ammonia in AdBlue is highly toxic and corrosive, and in contact with tissues can cause serious burns or even death.

Wear protective clothing and goggles to avoid contact with the tissues.

In case of contact with tissues, rinse thoroughly with plenty of water and get medical care.

Before working on the AdBlue supply system, read the safety information given in the section "information regarding AdBlue".

Replacement

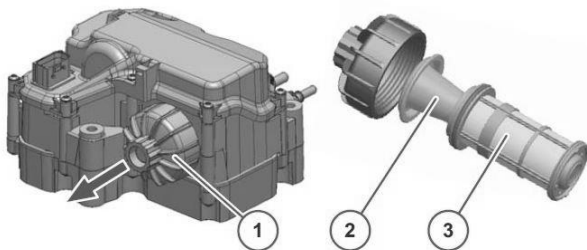

(1) cover, (2) compensator, (3) filter cartridge.

Proceed with replacement of the filter cartridge of the AdBlue supply pump by following the indications given:

- switch the engine off,
- disconnect the electric terminals,
- place a suitable sized container under the pump and filter to hold the liquid flowing out.
- remove the cover using a 27 mm HH wrench.
- remove the compensator and filter element completely,
- replace the filter element and refit it together with the compensator,
- fit the cover by applying a 22 ± 2.5 Nm tightening torque,
- reconnect the electrical system,
- start up the engine.

For drive units satisfying the TIER IV anti-pollution standards, in order to protect the AdBlue purification system, wait at least 5 minutes after the I.C. engine is switched off, before acting on the main electric circuit to disconnect it.

Coolant



DANGER OF BURNS

The coolant is pressurised and at high temperature with the engine switched on. When the cap is removed, the liquid may flow out violently and cause serious burns.

Make sure the engine is cold before working on the cooling system.

Checking

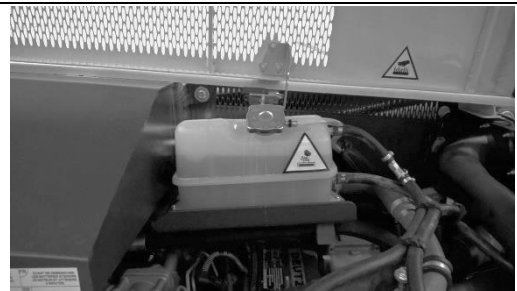

Set the vehicle in the parking position.

Check the level in the expansion tank placed above the radiator. The level is correct when it is half-way on the inspection window.

Open the tank, check the coolant additive concentration ratio using the instrument concerned (e.g. hydrometer, refractometer)

If necessary, top up with a suitable mixture depending on the use.

Refit the cap and make sure it is tightened properly. Run the engine to bring it to the required temperature. Switch off the engine and check for leaks in the circuit.

Bleeding the cooling system

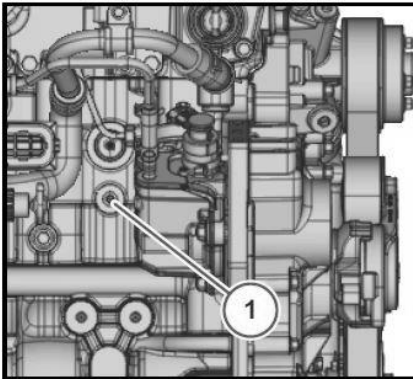

Set the vehicle in the parking position.

Remove the radiator cap carefully to release the residual pressure.

Place a suitable-sized container under the drainage cap to collect the coolant flowing out.

Remove screw (1) and drain out the coolant. If the screw is not accessible, drain through the engine oil radiator (coolant duct).

Refit the screw by applying mastic.

Refit the radiator cap

Differentials oils

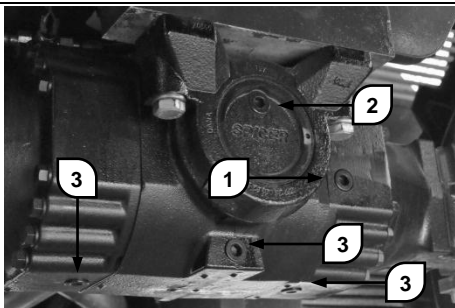

Checking

Set the vehicle in the parking position. Make sure no one approaches the work area.

Remove filler cap 1. The oil must flow out through the opening.

If necessary, remove filler cap 2. Add oil to the correct level. Close level cap 1, and then filler cap 2. Clean the axle surfaces.

Repeat the operations for the front and rear differential.

Replacement

Place suitable sized containers under the axle. Remove the three drainage caps of the differential 3. Wait for the oil to drain out completely. To speed up the operation, remove filler cap 2.

Refit caps 3 and tighten adequately. Remove filler cap 1.

Pour fresh oil of the correct type through hole 2. Fill in stages and check the flow of oil through level hole 1.

When the correct level is reached, refit level cap 2 and filler cap 3.

Repeat the operations for the front and rear differential.

Hydraulic fluid

Checking

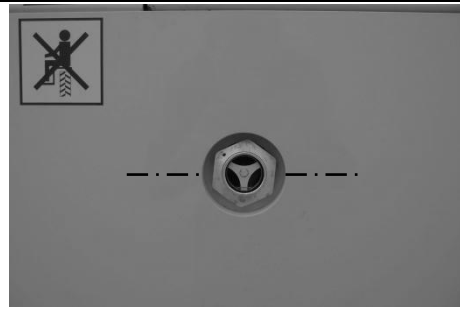

The hydraulic fluid tank is on the LH side of the vehicle. Check the hydraulic fluid level through the inspection window present on the tank.

The oil level is correct if it is halfway on the window, as shown by the dashes in the Figure.

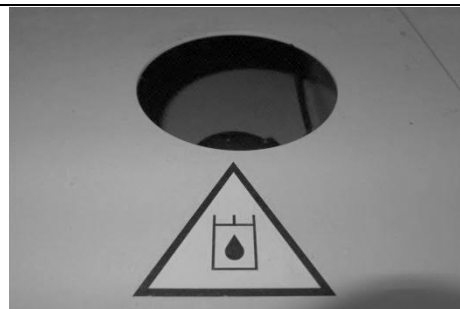

To top up the oil level, open the cap at the top of the tank. Pour oil of suitable strength up to the correct level. Refit the cap and tighten it manually.

Replacement

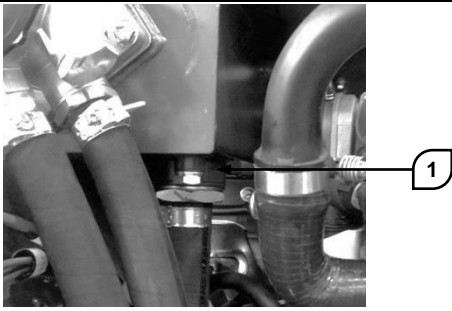

Open the engine compartment and place a funnel connected to a tank placed on the ground for recovering oil, under the threaded drainage cap, shown above. To speed up the operation, also unscrew the filler cap.

Refit drainage cap **1**, and fill the tank with fresh oil. Close the filler cap.

Start up the engine. Check to make sure there is space to extend the telescopic boom completely. Raise and lower the boom a number of times. Extend and retract the boom a number of times.

With the boom in the transport position, drive the vehicle carefully forwards. Steer the vehicle to the RH and LH.

Park the vehicle and check the oil level. Add oil if necessary.

Hydraulic fluid filter



ATTENTION

The machines use a single filter for hydraulic fluid: the filter placed inside the engine compartment has the combined function for oil at the suction as well as return.



Park the vehicle on a level surface, clean the filter housing and the surrounding areas to prevent dirt from entering the circuit. Unscrew the cap.

Replacement of the filter cartridge does not necessary involve drainage of the tank: the filter

housing has a special closure system. When it is being removed, the oil present inside the filter normally flows out

Remove the filter cartridge and dispose of according to the regulatory standards in force. Insert a new filter cartridge of the same type.

Refit the filter cover. Start up the engine and check for leaks.

Check for a drop in the oil level through the window present on the tank: if required, top up with the quantity necessary to reach the correct level.

Two or three-speed reduction gear oil

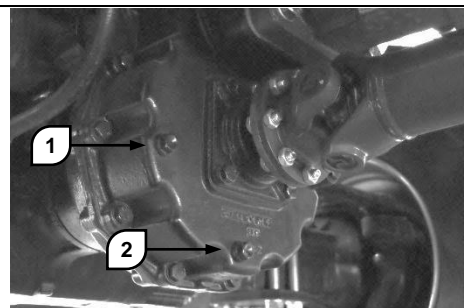

Checking

Set the vehicle in the parking position. Make sure no one approaches the work area.

Remove cap **1**. Check the oil level: the level is correct if it reaches the base of the hole. Add oil if necessary.

Reposition and tighten cap **1**.

Replacement

Place a suitable sized container under the two-speed reduction gear.

Remove cap **1**. Remove the magnetic drainage cap **2**. Wait for the oil to drain out completely.

Clean magnetic cap **2** to remove iron filings, then refit and tighten it.

Fill the reduction gear with oil through hole **1** up to the prescribed level. Reposition and tighten cap **1**.

Wheel reduction gears oil

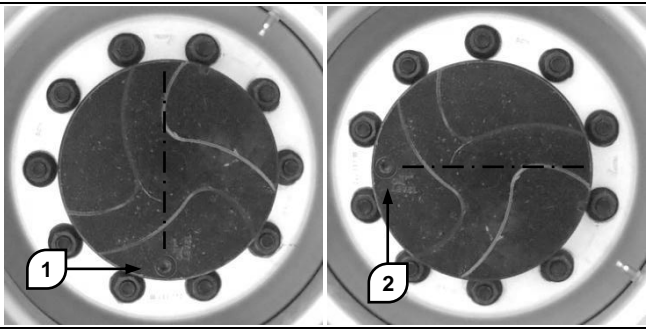

Checking

Set the vehicle in the parking position. Turn the reduction gear cap in the horizontal position **1**.

Remove the cap. The oil level is correct when the oil flows out through the filler hole.

If necessary, top up with oil (photo) **2** to the correct level.

Refit the cap. Repeat this operation for each wheel.

Replacement

Place a suitable sized container under the reduction gear. Turn the reduction gear cap in position **1**.

Remove the cap and wait for the oil to drain out completely.

Turn the reduction gear cap in position **2**. Fill oil through the hole to the correct level.

Refit the cap. Repeat this operation for each wheel.

Steering elements

Lubrication

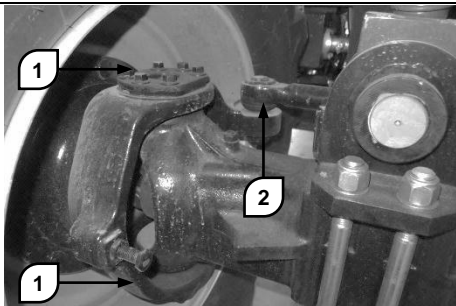

Lubricate the wheels rotation pins **1** by injecting grease in the grease nipples provided for the purpose. Remove the excess grease.

Lubricate the ball joint **2** injecting grease in the grease nipples provided for the purpose. Remove the excess grease.

Repeat the operations for each wheel.

Engine air filter

The efficiency and life of the engine depend greatly on the quality of air taken in. A dirty or damaged air filter can seriously affect the correct working of the engine and increase the possibility of a fault.

Replace the air filters strictly according to the schedule indicated in this Manual. Do not try to wash dirty filters.

If the machine is expected to be used in environments with a lot of dust or high concentrations of contaminating or polluting agents in the air, halve the time interval between one filter replacement and the next.

Replacing the primary cartridge

To access the filter housing, open the engine compartment



Release the catches and remove the cover on the front of the filter.

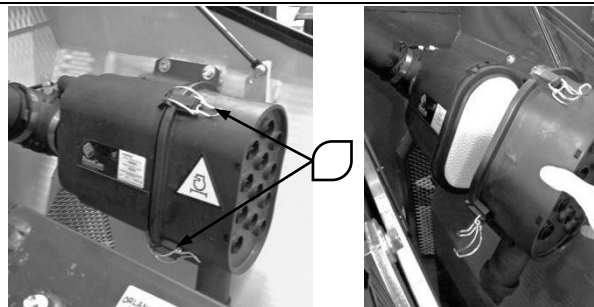

Grip the filter element and remove it from its seat.



Wipe thoroughly inside the filter housing with a damp cloth. Avoid the use of aggressive solvents or products as these can damage the safety filter or the filter housing.

Install a new filter element. Make sure the filter element is inserted properly in its seat. If installation is difficult, grease the rubber gasket slightly with silicone grease.

Replacement of safety cartridge

Carry out the primary filter removal procedure described earlier.

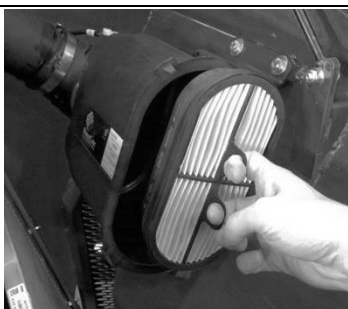

Hold the filter element by means of two fingers in the grips and pull to separate it from its seat.

Wipe thoroughly inside the filter housing with a damp cloth. Avoid using aggressive solvents or chemical products as these can damage the filter casing.

Install a new filter element. Grease the outer gasket of the new filter element slightly with silicone grease.

Cab air filter

Replacement

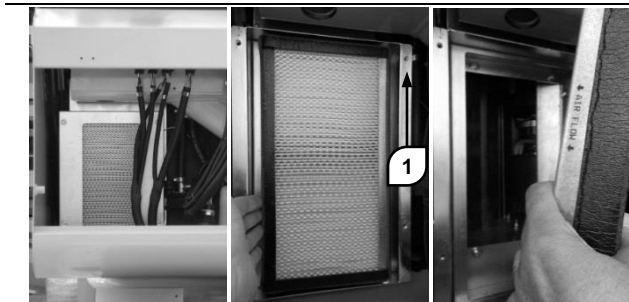

Open the compartment in the rear part of the cab to access the filter housing.

Unscrew the four screws **1** and remove the filter holder frame.

Remove the air filter and replace it with a new one of the same type.

For reassembly repeat the above operations in reverse order. Check the correct direction of assembly before fitting the holder frame.

Telescopic boom sliding blocks

Checking

Extend the telescopic boom completely.

Check to make sure the boom movement is smooth. Ensure that there are no abnormal vibrations, unusual noises, and no part of the boom gets heated due to friction during the movement.

Check for the presence of a sufficient layer of grease on the sliding surfaces and on the sliding blocks.

Lubrication

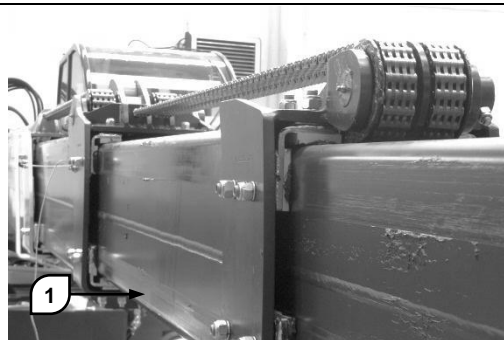

Park the vehicle in a suitable sized area, and rest the stabilisers on the ground. Remove the accessory from

the quick-fit coupling. Centre the front axle of the forklift truck (sliding) and place the telescopic boom in the horizontal position. Extend the telescopic boom completely.

Clean all the sliding surfaces thoroughly.

Using a brush, apply a thin layer of grease on the sliding surfaces on all four sides of the boom. Repeat the operation for each stage of the extension.

Retract and extend the telescopic boom a number of times to distribute the grease uniformly.

Remove excess grease to prevent accumulation of dirt.

Adjusting the play

Park the vehicle in a suitable sized area, and rest the stabilisers on the ground. Remove the accessory from the quick-fit coupling. Centre the front axle of the forklift truck (sliding) and place the telescopic boom in the horizontal position. Retract the telescopic boom completely.

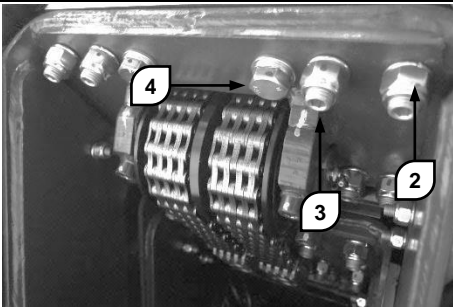

Remove the cover on the rear part of the boom.

Slacken all the lock nuts **2** of the upper and lower sliding blocks of the first extension stage. Fit all the screws **3** all the way without tightening them, then tighten through half a turn.

Tighten each lock nut holding the relative screw firm. Also tighten the fixing screws **4**. Tightening torque: 100 Nm.

Repeat the adjustment operations for the lateral sliding blocks. Try to adjust the sliding blocks in such a way that the screws project to the same extent.

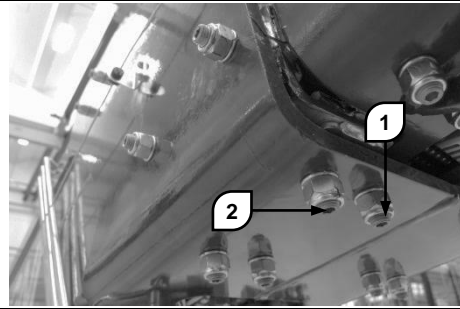

Move to the front of the boom, and identify the sliding blocks of the first extension stage.

Slacken all the lock nuts **1** of the upper and lower sliding blocks. Fit all the screws **2** all the way without tightening them, then tighten through half a turn.

Tighten each lock nut holding the relative screw firm. Tightening torque: 100 Nm.

Repeat the adjustment operations for the lateral sliding blocks. Try to adjust the sliding blocks in such a way that the screws project to the same extent.

Repeat the operations described above for the sliding blocks of all the extension stages, proceeding in order towards the front part of the boom.

Always try to adjust the sliding blocks symmetrically, so that each stage is centred with respect to the adjacent ones.

After completing the operations try to extend and retract the boom to check the boom movement is smooth. If the movement of the boom is not smooth, repeat the adjustments, unscrewing the screws through one complete turn instead of through half a turn.

Contact your dealer for clarification or for assistance.

Telescopic boom pins

Lubricate the pins of the movable parts of the telescopic boom at regular intervals. Lack of lubrication can cause seizure of the pins in their seats.

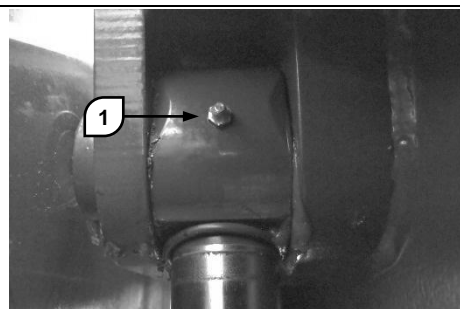

Set the vehicle in the parking position, unless otherwise specified.

Identify the grease nipples **1** and inject grease into these until it flows out from the edges of the pins.

Wipe excess grease to prevent accumulation of dirt.

Lubrication of boom pin

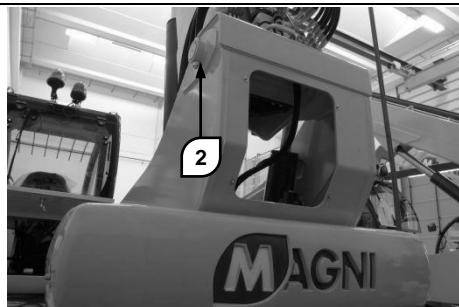

Lubricate pin **2** injecting grease in both grease nipples present on the boom.

Lubrication of lift cylinder pins

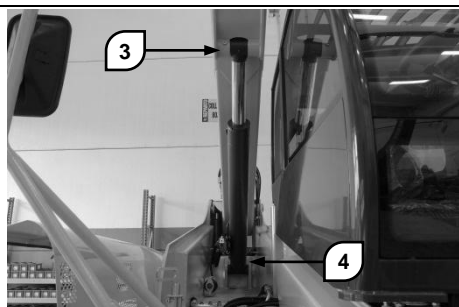

Lubricate pins **3** and **4** of the lift cylinder. To make access to the grease nipples easier, lift the telescopic boom completely.

Lubrication of compensation cylinder pins

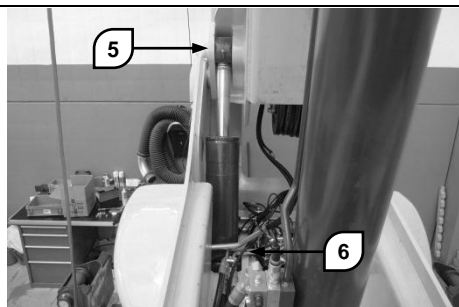

Lubricate pins **5** and **6** of the compensation cylinder. To make access to the grease nipples easier, lift the telescopic boom completely.

Lubrication of quick-fit coupling pin



Lubricate the pin of quick-fit coupling **7** through the grease nipples.

Lubrication of slewing cylinder pins

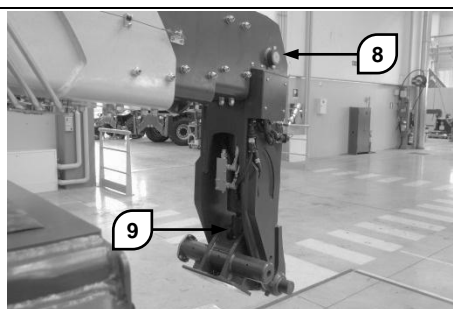

Lubricate pins **8** and **9** of the slewing cylinder by means of the grease nipples provided on the cylinder.

Emergency hydraulic pump

Operating test



ATTENTION

This model is fitted with a mechanically operated emergency hydraulic pump placed inside the rear guard of the vehicle chassis.

If there is malfunctioning of the hydraulic pump activated by the I.C. engine, two operators are required, one inside the machine cab and another outside, to use this pump.

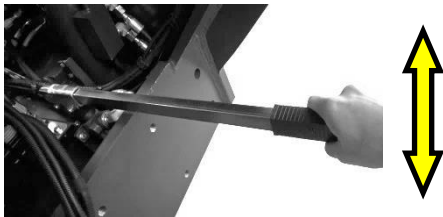
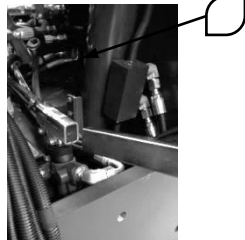

Set the vehicle in the parking position. Extend and raise the telescopic boom, switch off the I.C. engine keeping the electric circuit powered and the electronic control board of the forklift truck active.

Remove the rear guard on the vehicle chassis and take the pump activation lever out of its seat on the LH side of the chassis.

Insert the lever in the pump seat then start movement vertically as shown.

At the same time, activate the controls from the cab to lower and retract the telescopic boom.



ATTENTION

In case of a fault in the emergency hydraulic circuit, avoid using the machine and contact your dealer.

Engine radiator

Cleaning

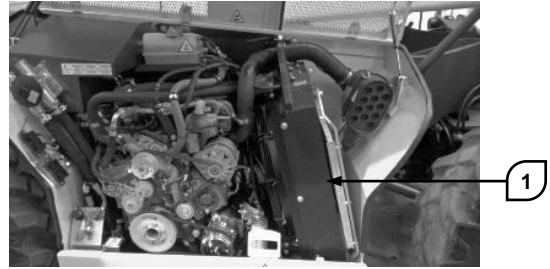

To remove dust and debris from the radiator mass, compressed air, pressurised water or steam can be used. However, it is preferable to use compressed air.

When using pressurised water, keep the high pressure jet cleaning nozzles at a distance of at least 50 cm from the radiator mass. Bringing the nozzle too close to the radiator mass can lead to risk of damaging the radiator.

Wheels

Checking the tyre pressure

Set the vehicle in the parking position.

Clean the area around the valve stem. Remove the protective cap from the valve stem.

Measure the pressure of each tyre using a pressure gauge. If the pressure is different from that prescribed, make the necessary adjustments.

Refit the protective cap.

Checking the tightening of the nuts

Set the vehicle in the parking position.

Check the tightening torque of the new wheels. Check the tightening torque of the repaired wheels.

Tighten the wheel nuts in the cross-wise sequence applying the correct tightening torques.

The checking must be done every 10 hours of service, until the torque remains constant. It is then possible to return to normal checking intervals.

The tightening torque of the wheel nuts is 630 Nm. The tightening torque is shown on the plate affixed to the chassis near the axles.

Fuel tank

Refuelling

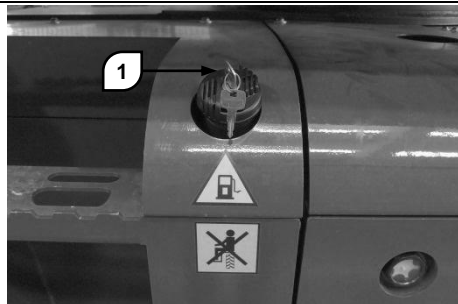

Set the vehicle in the parking position. Switch the engine off.

Unlock the tank cap using wrench **1**. Unscrew the tank cap by turning it counter-clockwise.

Refuel using suitable fuel. Screw the fuel cap in and lock using wrench **1**.

Cleaning

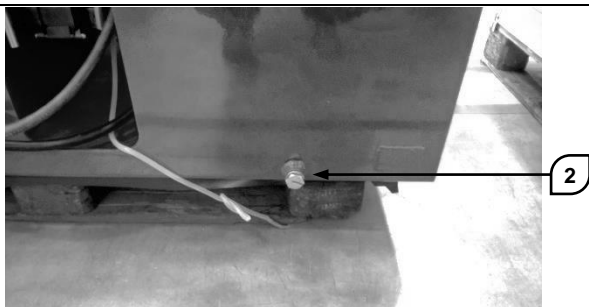

Unscrew the filler cap. Place a suitable sized container under the fuel tank near drainage cap **2**.

Unscrew drainage cap **2**, and drain out the tank completely.

Pour 10 litres of clean fuel into the tank to rinse out impurities that may be present at the bottom.

Close and tighten drainage cap **2**. Fill the tank with clean fuel. Check to make sure there are no leaks.

Window washing liquid tank

Filling

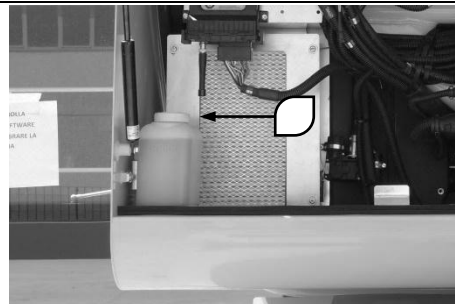

Open the compartment in the rear part of the cab to access the window washing liquid tank housing.

Unscrew the cap by turning it counter-clockwise. Fill the tank with window washing liquid, leaving about 1 cm between the liquid level and the edge.

Refit cap **1** and tighten it by hand.

Stabilizers

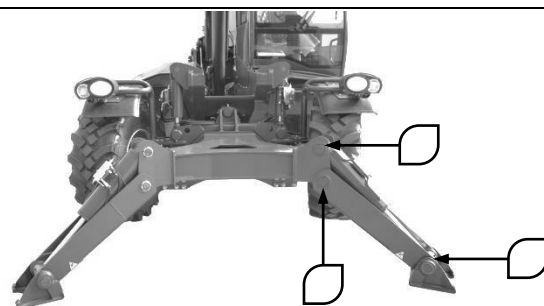

Set the vehicle in the parking position. Lower the stabilisers completely to the ground for easier access to the areas to be lubricated.

Lubricate all the rotation pins of the stabilisers, including the pins of the hydraulic cylinders. Lubricate by injecting grease in the grease nipples present on each pin. Wipe excess grease to prevent accumulation of dirt.

Operate the hydraulic movement of the stabilisers a number of times to distribute the grease uniformly. Make sure the stabiliser foot oscillates freely. Increase the lubrication frequency of the base support pin if necessary.

Engine Trouble-shooting

Engine – does not switch on or switching on is difficult (no fumes at exhaust)

Cause	Solution
No fuel in tank	Refuel
Ignition switch defective	Check the opening and closing of the electric connection.
Fuel filter clogged.	Bleed the water separator or replace the filter.
Fuel priming pump defective.	Check to make sure the pump provides the flow rate suitable for the high pressure pump. Check the electrical connections.
Air in the fuel	Check the absence of air returning to the circuit
Fuel dirty or non conforming	SWITCH THE ENGINE OFF. Replace the fuel filters. Run the engine with correct fuel.
Suction or discharge system obstructed	Visually inspect the suction and discharge, and remove any obstructions present. Replace the air filter if necessary
Fuel return line blocked	Check to make sure the line is clear and connected to the upper part of the tank
Fault in one or more injectors	Check the electrical connections.
ECU or sensors fault	Check the electrical connections.

Engine – Does not rotate when started up or moves slowly

Cause	Solution
Electric circuit elements slackened or worn	Clean and carry out the necessary maintenance
Battery flat	Check the voltage using a multimeter. Check the working of the alternator.
Solenoid or starter motor fault	Replace the starter motor
Starter motor working but the engine does not rotate	Remove the starter motor and check the state of the gears and spring

Engine – Starts up but switches off immediately

Cause	Solution
No fuel in tank	Refuel

Cause	Solution
Starter motor charged	Check the presence of external loads due to faulty auxiliaries
Suction or discharge system obstructed	Visually inspect the suction and discharge, and remove any obstructions present. Replace the air filter if necessary
Fuel priming pump defective.	Check to make sure the pump provides the flow rate suitable for the high pressure pump. Check the electrical connections.
Fuel frozen	Use fuels suitable for low temperatures
Air in the fuel	Check the absence of air returning to the circuit
Fuel dirty or non conforming	SWITCH THE ENGINE OFF. Replace the fuel filters. Run the engine with correct fuel.
Fuel supply obstructed	Check for blockage along the line. Check the state of the filters and replace if necessary.
Fuel return line blocked	Check to make sure the line is clear and connected to the upper part of the tank
ECU or sensors fault	Check the electrical connections.

Engine – irregular operation

Cause	Solution
Engine cold, or coolant temperature sensor fault	Check the sensor electrical connection. Check the working of the sensor.
Leakage in fuel circuit	Replace the defective connections. DO NOT try to carry out repairs.
Air in the fuel	Check the absence of air returning to the circuit
Fuel priming pump defective.	Check to make sure the pump provides the flow rate suitable for the high pressure pump. Check the electrical connections.
Fuel supply obstructed	Check for blockage along the line. Check the state of the filters and replace if necessary.
Fuel dirty or non conforming	SWITCH THE ENGINE OFF. Replace the fuel filters. Run the engine with correct fuel.
Incorrect adjustment of valve play	Correct the adjustment
Compression not good in one or more cylinders	Check the compression ratio

Cause	Solution
ECU or sensors fault	Check the electrical connections.

Engine – excessive noise

Cause	Solution
Slipping of transmission belt, tension insufficient or excessive	Check the belt tensioner and inspect the belt. Make sure the pulley rotation is not hindered
Coolant temperature sensor fault	Check the sensor electrical connection. Check the working of the sensor.
Fuel dirty or non conforming	SWITCH THE ENGINE OFF. Replace the fuel filters. Run the engine with correct fuel.
Incorrect adjustment of valve play	Correct the adjustment. Make sure the rod and equaliser mechanism is not damaged or worn
Noise coming from engine block	Contact your dealer immediately

Engine – reduced power

Cause	Solution
No fuel in tank	Refuel
Oil level not correct	Check the level
Engine overload	Check the presence of overloads due to faulty auxiliary parts
Fuel dirty or non conforming	SWITCH THE ENGINE OFF. Replace the fuel filters. Run the engine with correct fuel.
Fault in turbocompressor	Contact your dealer
Leakage in fuel circuit	Replace the defective connections. DO NOT try to carry out repairs.
Fuel supply obstructed	Check for blockage along the line. Check the state of the filters and replace if necessary.
Air in the fuel	Check the absence of air returning to the circuit
Fuel priming pump defective.	Check to make sure the pump provides the flow rate suitable for the high pressure pump. Check the electrical connections.
Suction or discharge system obstructed	Visually inspect the suction and discharge, and remove any obstructions present. Replace the air filter if necessary

Cause	Solution
Fault in one or more injectors	Check the electrical connections.
Leaks in manifolds or in turbocompressor	Check and correct leaks in the manifolds
Too many sealing washers installed under the injectors	Remove the excess sealing washers.
Incorrect adjustment of valve play	Correct the adjustment
Compression not good in one or more cylinders	Check the compression ratio

Engine – Does not reach the maximum rpm

Cause	Solution
Speedometer defective	Check the engine speed using a manual speedometer. Correct if necessary
Engine overload	Check the presence of overloads due to faulty auxiliary parts
Fuel dirty or non conforming	SWITCH THE ENGINE OFF. Replace the fuel filters. Run the engine with correct fuel.
Wastegate valve actuator diaphragm cracked	Repair or replace the turbocompressor
Leakage in fuel circuit	Replace the defective connections. DO NOT try to carry out repairs.
Fuel supply obstructed	Check for blockage along the line. Check the state of the filters and replace if necessary.
Fuel priming pump defective.	Check to make sure the pump provides the flow rate suitable for the high pressure pump. Check the electrical connections.
Fault in one or more injectors	Check the electrical connections
Fuel high pressure pump fault	Contact your dealer

Engine – Excessive vibrations

Cause	Solution
Oil level excessive	Check the level
Fan damaged or auxiliaries fault	Replace the defective components
Fan hub damaged	Check and replace the hub

Cause	Solution
Engine supports slackened or damaged	Tighten the slackened supports and replace those that are damaged
Incorrect adjustment of valve play	Correct the adjustment
Compression not good in one or more cylinders	Check the compression ratio
Alternator bearing worn	Check/replace the alternator

Engine – black fumes at the exhaust

Cause	Solution
Suction or discharge system obstructed	Visually inspect the suction and discharge, and remove any obstructions present. Replace the air filter if necessary
Leaks between the turbocompressor and suction manifold	Inspect and repair the leaks
Intercooler defective	Check the radiator mass
Leaks from discharge manifolds or from turbocompressor	Repair the leaks from the gaskets. Check for cracks in the connections
Wastegate valve fault	Replace the valve
Turbocompressor fault	Replace
Fault in one or more injectors	Check the electrical connections
Compression not good in one or more cylinders, fumes with load mainly at average and low speeds	Contact your dealer

Engine - white fumes at the exhaust

Cause	Solution
Fuel dirty or non conforming	SWITCH THE ENGINE OFF. Replace the fuel filters. Run the engine with correct fuel.
Oil level not correct	Check the level
Diesel and hydraulic oil in engine casing	In case of contamination of oil check the gaskets near the PTO. Drain oil, clean and refill with fresh oil
Leaks from seals in the valve seats – evident after long periods at minimum speed followed by sudden acceleration	Contact your dealer

Cause	Solution
Fault in one or more injectors	Check the electrical connections
Piston belts not sealed – blue fumes at all speeds	Contact your dealer

Restrictions to the working due to malfunctioning of the UREA/AdBlue system.

The drive units satisfying the stage IV regulatory standards are provided with special control software for limiting their working until they are switched off for precautionary purposes if there are problems in the UREA/AdBlue purification systems. Specifically, the problems can be summarised as follows:

- low level of urea in tank
- poor quality of urea liquid
- tampering with the urea system
- system errors

Depending on the extent of the anomaly, in order to protect the thermal unit, the software controls a power reduction at two levels:

- level 1: torque reduction,
- level 2: torque and engine rpm reduction



A separate safety button is provided for temporary deactivation of the power reduction caused by the system.

This function can only be activated for a limited period to allow the operator to park the vehicle in a safe place.

In compliance with EU legislation, the function is available for engines with level 1 and 2 power reduction, while in compliance with EPA legislation, it is only available for level 1 power reduction.



AdBlue® level

Beginning of warning signals starting from AdBlue filling level less than 15 %.

AdBlue® level	SCR indicator light 	Engine indicator light 	Power reduction	
			EU	EPA
<15%	Permanent light	off	none	none
<10%	flashing (0.5 Hz)	off	none	none
<5%	flashing (0.5 Hz)	Acoustic signal permanent light	none	none
<5% ≥ 10 min	flashing (1 Hz)	Acoustic signal permanent light	Level 1	none
<5% ≥ 15 min	flashing (2 Hz)	flashing acoustic signal	Level 1	none
<5% ≥ 20 min	flashing (2 Hz)	flashing acoustic signal	Level 2	Level 2



Efficiency of catalyst/AdBlue® quality

If the efficiency of the catalyst is too low (yield percentage), even if the level has already been topped up, warning messages are sent to the SCR function or optional CAN display. The warning signals are also transmitted if an unsuitable reducing agent is used.

Efficiency of catalyst/AdBlue® quality	SCR indicator light 	Engine indicator light 	Power reduction	
			EU	EPA
Excessively low	Acoustic signal permanent light	Permanent light	Level 1 after the prealarm	none
too low not solved	Acoustic signal permanent light	flashing	Level 2 after the prealarm	Level 2 after the prealarm period



Manipulation

If the system detects the presence of a component that has been manipulated or if an unsuitable reduction agent has been used, the power is reduced. The power reduction takes place gradually and depends on the engine power.

Manipulation	SCR indicator light 	Engine indicator light 	Power reduction	
			EU	EPA
recognized	Acoustic signal permanent light	Permanent light	Level 1 after the prealarm period	none
not solved	Acoustic signal permanent light	flashing	Level 2 after the prealarm period	Level 2 after the prealarm period

System errors

System errors may concern problems involving the individual SCR components, including an implausible value of Nox level or temperature sensor. If the AdBlue® injection cycle is affected by a system error, the power is reduced.

System errors	SCR indicator light 	Engine indicator light 	Power reduction
recognized	Acoustic signal permanent light	flashing	none
recognized ≥ 10min	Acoustic signal permanent light	flashing	Level 2

In power limitation condition, the forklift truck driver can display the errors page on the control panel by pressing

the alarm button , and activate the OVERRIDE function 3 times by means of the button concerned: this allows the engine to run at full speed for 30 minutes bypassing the errors detected.

Once the errors detected have been rectified, the engine returns to operation at its full capacity but without the errors being cancelled from the memory of the control unit.

Fuel – excessive consumption

Cause	Solution
Additional loads on the engine	Check/repair the auxiliaries and equipment of the forklift truck
Fuel leaks	Check for leaks near the tank, fuel line, filters and priming pump. DO NOT try to repair the defective piping
Control unit defective	Contact your dealer
Fault in one or more injectors	Check the electrical connections
Incorrect adjustment of valve play	Correct the adjustment

Fuel/oil – leaks from the drainage

Cause	Solution
Turbocompressor lubrication line obstructed	Check and clean the piping
Leaks from discharge manifolds or from turbocompressor	Repair the leaks from the gaskets. Check for cracks in the connections
Leaks from the valve guides	Contact your dealer
Control unit defective	Contact your dealer
Fault in one or more injectors	Check the electrical connections

Lubricant – excessive consumption

Cause	Solution
Oil leaks	Check the engine for leaks
Lubricant specifications unsuitable	Make sure a suitable lubricant is used. Check contamination by fuel
Leaks in cooling system	Check for the presence of lubricating oil in the coolant
Leaks from turbocompressor in the suction or discharge system	Check for leaks
Leaks from the valve guides	Contact your dealer
Cylinders worn or damaged	Contact your dealer

Lubricant - contamination

Cause	Solution
--------------	-----------------

Cause	Solution
Oily deposit in lubricant	Change the oil and filters. If operating in particularly heavy duty conditions, increase the maintenance frequency. Make sure a suitable lubricant is used
fuel in lubricant oil, engine temperature very low	Avoid leaving the engine running at low speed for too long

Lubricant - pressure excessively low

Cause	Solution
Oil level not correct	Check the level
Lubricant specifications unsuitable	Make sure a suitable lubricant is used. Check contamination by fuel
Pressure gauge fault	Check the correct working
Oil filter clogged	Change the oil and filters. If operating in particularly heavy duty conditions, increase the maintenance frequency. Make sure a suitable lubricant is used
The oil priming pump pressure limiter valve is blocked in the open position	Contact your dealer
The oil pump pressure limiter valve is blocked in the open position	Contact your dealer
Oil pump worn	Contact your dealer

Lubricant – excessive pressure

Cause	Solution
Lubricant specifications unsuitable	Make sure a suitable lubricant is used. Check contamination by fuel
Pressure gauge fault	Check the correct working
The oil pump pressure limiter valve is blocked in the closed position	Contact your dealer

Coolant - leaks

Cause	Solution
Coolant level not correct	Check the level
Liquid leaks from radiator	Check the radiator, hoses and piping for leaks

Cause	Solution
Liquid leaks from engine	Check the engine for leaks from gaskets, pipes or unions. Make sure all the clamps are tightened properly and in good condition
Leaks from the head gasket	Contact your dealer
Engine head cracked or shows porosity	Contact your dealer
Leaks from lubricant passages in the base	Contact your dealer

Coolant - overheating

Cause	Solution
Coolant level not correct (low)	Check the level
Radiator grille obstructed.	Clean the radiator grille
Air flow to radiator insufficient or obstructed	Check/repair the fan
Belt tension insufficient	Check the tension
Radiator tube crushed, obstructed or cracked	Check/replace the defective tube
Oil level not correct (high)	Check the level
Radiator cap defective	Replace the radiator cap
Excessive concentration of anti-freeze	Drain part of the circuit and fill with distilled water
Temperature sensor defective	Check the accuracy of the sensor
Thermostat faulty or missing	Check/replace the thermostat
Coolant pump faulty	Check/replace the pump
Passage of liquid through the radiator, head or engine block obstructed	Wash the plant with distilled water and fill with fresh coolant

Coolant – not at required temperature

Cause	Solution
Temperature sensor defective	Check the accuracy of the sensor
Thermostat defective (blocked open)	Check/replace the thermostat
Liquid not circulating near the temperature sensor	Check/clean the liquid passages

REFERENCE INFORMATION

Leaving the vehicle unused for long periods

If the vehicle is to be left unused for more than 30 days, carry out certain operations to keep it in good condition and maintain a high level of service.

Leaving the vehicle unused for less than 12 months

Park the vehicle in a well ventilated area, free of humidity and protected from atmospheric agents. Make sure the environmental temperature in the area does not fall below -10° C.

Clean the vehicle thoroughly. Remove all traces of rust or corrosion. Touch up the paint layer in the areas concerned.

Change the engine oil and the filter if the oil is more than 12 months old or after 300 hours of service after the last change.

Charge the batteries. Check the level of electrolyte before and after charging. Disconnect the negative pole after the charging.

Check the liquid level and top up if necessary.

Check the pressure in the AdBlue circuit pressure accumulator.

Dismantling and disposal of the machine

When the machine is out of service, the reference standards will have changed. The procedures for dismantling and scrapping the machine vary according to the regulatory standards in force in the country in which it is used.

For information regarding dismantling and scrapping the machine, contact your dealer for updates regarding the directives in force.

Drain water from the fuel prefilter with water/diesel separator.

Close the drainage tube and the air intake in the filter casing with rags soaked in oil.

Slacken the belt tensioner device in the transmission belt. Do not dismantle the transmission belt completely.

Reusing the vehicle

Clean the fuel tank. Refuel

Replace the fuel prefilter and filter.

Check the coolant level. If topping up is necessary, take a sample of the liquid and check the composition. Add distilled water or pure liquid to adjust the composition.

Check the battery charge. Charge if necessary. Check the level of electrolyte before and after charging. Again connect the negative pole to the batteries. Check the electrical system to make sure it is working correctly.

Check the condition of the transmission belt. Replace if necessary. Restore the working of the belt tensioner device.

Start up the engine and let it run for 15 – 30 minutes at not more than 900 rpm. Keep the oil pressure, water temperature and oil temperature indicators under observation.

Check the oil level in the axles, in the wheel reduction gears and in the gearbox.

APPROVED ACCESSORIES



ATTENTION

Using accessories that are not approved for use on the machine can cause accidents or even death.

Before installing an accessory on the machine, make sure it has been approved by Magni Telescopic Handlers s.r.l., and that the corresponding load charts are present in the machine management software.

The code of the accessory manufactured by Magni Telescopic Handlers s.r.l. is stamped on its identification plate. To establish whether an accessory is approved, contact the dealer or the Customer Service directly.

Some accessories produced by other manufacturers can be adapted for fitting on the machines described in this Manual. Contact your dealer to know if your accessory can be adapted for assembly on your machine.

If the accessory is suitable and before proceeding, the accessory and the machine must be sent to the dealer for the required modifications and tests. At the end of the procedure a certificate of conformity will be issued.

It is forbidden to use an accessory not accompanied by the certificate of conformity. It is also forbidden to use any accessory on your vehicle if the certificate of conformity does not confirm the compatibility.

DELIVERING THE FORKLIFT TRUCK TO THE CUSTOMER

Machine model	
Serial No.	
Year of manufacture	

for which the Inspection Register is being handed over by

Magni Telescopic Handlers S.r.l.

Via Magellano, 22

41013 Castelfranco Emilia (MO) Italy

Tel +39-059-8630811 Fax +39-059-8638012

by Mr. _____

to the Company _____

Street _____

Post Code – City _____ province _____

represented by Mr. _____

according to the conditions defined in the contract, with the technical, dimensional and functional features specified in the attached Use and Maintenance Manual.

on

The Dealer

for the Customer/Buyer

Registration of change of ownership

on _____

The ownership of the vehicle identified in this Register was transferred to:

Company _____ represented by Mr. _____

Street/No. _____ Post Code/City _____

prov. _____

It is hereby declared that, at the time of preparation of this document, the technical, dimensional and functional features of the vehicle described in this Register conform to those indicated at the beginning by the Manufacturer and that changes, if any, have been recorded.

Furthermore, we declare that the transfer has been reported to the relevant Bodies (local INAIL).

The Dealer

The Buyer

Registration of change of ownership

on _____

The ownership of the vehicle identified in this Register was transferred to:

Company _____ represented by Mr. _____

Street/No. _____ Post Code/City _____

prov. _____

It is hereby declared that, at the time of preparation of this document, the technical, dimensional and functional features of the vehicle described in this Register conform to those indicated at the beginning by the Manufacturer and that changes, if any, have been recorded.

Furthermore, we declare that the transfer has been reported to the relevant Bodies (local INAIL).

The Dealer

The Buyer

Registration of change of ownership

on _____

The ownership of the vehicle identified in this Register was transferred to:

Company _____ represented by Mr.

Street/No. _____ Post Code/City _____

prov. _____

It is hereby declared that, at the time of preparation of this document, the technical, dimensional and functional features of the vehicle described in this Register conform to those indicated at the beginning by the Manufacturer and that changes, if any, have been recorded.

Furthermore, we declare that the transfer has been reported to the relevant Bodies (local INAIL).

The Dealer

The Buyer

Registration of change of ownership

on _____

The ownership of the vehicle identified in this Register was transferred to:

Company _____ represented by Mr.

Street/No. _____ Post Code/City _____

prov. _____

It is hereby declared that, at the time of preparation of this document, the technical, dimensional and functional features of the vehicle described in this Register conform to those indicated at the beginning by the Manufacturer and that changes, if any, have been recorded.

Furthermore, we declare that the transfer has been reported to the relevant Bodies (local INAIL).

The Dealer

The Buyer
